

# Makumbebé II

## Latin American Choral Repertoire

for equal voices

11 songs from Bolivia, Brazil  
Chile, Colombia, Costa Rica, Cuba  
Guatemala, Mexico and Venezuela

edited by María Guinand

Carmina mundi



International Federation for Choral Music

 Carus 2.502

## Contents

Title	Text (T) / Music (M) / Choral version (C.v.)	Country	Page
1. He venido a despedirme . . . . .	T/M: Anonymous, from the province of Sucre . . . . . C.v.: Jesús Ochoa . . . . .	Bolivia . . . . .	5
2. Cana-fita . . . . .	T/M: Brazilian folk-song . . . . . C.v.: Eduardo Lakschevitz . . . . .	Brazil . . . . .	10
3. Natal . . . . .	T/M: Ernani Aguiar . . . . .	Brazil . . . . .	16
4. Cántica N° 8 . . . . .	T/M: Luis Antonio Escobar . . . . .	Colombia . . . . .	22
5. El torito . . . . .	T/M: Typical dance from Costa Rica . . . . . C.v.: Pedro Antonio Silva . . . . .	Costa Rica . . . . .	27
6. Paisaje . . . . .	T: Felipe González . . . . . M: Guido López Gavilán . . . . .	Cuba . . . . .	33
7. La rosa y el clavel . . . . .	T/M: Folk song . . . . . C.v.: Jesús A. Hernández . . . . .	Chile . . . . .	41
8. El barreño . . . . .	T/M: Anonymous traditional . . . . . C.v.: Alberto Grau . . . . .	Guatemala . . . . .	46
9. La golondrina . . . . .	T/M: Narciso Serradell . . . . . C.v.: Alberto Grau . . . . .	Mexico . . . . .	50
10. Mariposa candorosa . . . . .	T: Rosa Carreto . . . . . M: José Antonio Rincón . . . . .	Mexico . . . . .	54
11. Aniceto Rondón . . . . .	T/M: Anonymous, trad. from Zulia State . . . . . C.v.: Jesús Ochoa . . . . .	Venezuela . . . . .	59
Text . . . . .			63
Pronunciation guide . . . . .			67
Program notes . . . . .			68
Biographies . . . . .			70

A CD featuring this music is available with the Cantoría Alberto Grau, Founding Conductor and Artistic Director: María Guinand, Conductor: Victoria Nieto (Carus 2.502/99). The CD is included in the conductor's edition. For additional volumes in the International Choral Series "Carmina mundi", see p. 72

Cover by Max Ackermann (1887–1975), Ackermann-Archiv Bietigheim-Bissingen, Germany

This painting, whose forms are connected by fine lines, could be interpreted to represent bridges spanning continents, nations, and cultures, and thus could portray music as a bridge of song.

Copying of pieces from this collection is prohibited. Separate editions of titles may be ordered in choral quantity from Carus ([www.carus-verlag.com](http://www.carus-verlag.com)). In addition the piece "Caracolitos chicos," from Venezuela, based on text fragments by Federico García Lorca with music by Alberto Grau, is available only as a separate edition (Carus 9.935) in choral quantity. It also appears on the CD recording indicated above.

## Preámbulo

Esta segunda colección *Makumbé II* de Repertorio Coral Latinoamericano para voces iguales está conformada por obras originales de autores contemporáneos y por una variada selección de versiones corales de melodías pertenecientes al acervo cultural de nuestra región.

El repertorio para voces iguales es menos extenso que el de voces mixtas, quizás porque el número de agrupaciones corales de esta naturaleza también es menor.

Ha sido nuestro deseo incorporar un variado espectro de obras, con diferentes niveles de dificultad, de manera de hacer accesible la colección a todo tipo de agrupaciones corales.

Algunos arreglos y composiciones originales son sencillos y agraciados, y las posibilidades de interpretación son variadas y flexibles. Otras obras, más complejas y difíciles, pero de excelente calidad, como *Paisaje* de Guido López Gavilán y *Caracolitos Chicos* de Alberto Grau (editada en forma individual por Carus 9.935) requieren de agrupaciones más experimentadas y de una preparación más profunda por parte de los directores.

A los largo de mis 30 años como directora fundadora de la Cantoría Alberto Grau, coro femenino pionero en Venezuela, he podido experimentar y dar a conocer todo este repertorio que hoy presentamos en esta colección impresa y en su correspondiente grabación. Es mi deseo que muchos coros puedan disfrutar haciendo esta música y transmitir a sus audiencias, a través de ella, el sentir del alma latinoamericana, sus ritmos y sus colores. Para ayudarles – si es necesario – a familiarizarse con el repertorio musical de diversas regiones de América Latina, he preparado una grabación de esta colección con la Cantoría Alberto Grau y algunos instrumentistas experimentados en estos géneros musicales.

Deseo expresar mi más profunda gratitud a Flor Angélica Martínez País por su dedicación y entusiasmo en el trabajo esmerado de copia de cada una de las partituras, y a Luimar Arismendi y Albert Hernández por la creación y ejecución de todas las partes instrumentales.

María Guinand

### Uso de instrumentos

Todo el acompañamiento instrumental en nuestra música popular es generalmente improvisado por músicos expertos en los diferentes estilos y conocedores de las sutilezas rítmicas. Sin embargo, en esta colección incorporamos para cada pieza una instrumentación acorde con las tradiciones musicales de la región a la cual pertenece, pero los directores pueden modificarlas utilizando otros instrumentos que les sean accesible, aunque en la medida de lo posible, es aconsejable utilizar la percusión sugerida. También se compusieron algunas melodías para introducciones o interludios, las cuales pueden ser igualmente recreadas o simplemente obviadas por el intérprete. Es claro que el acompañamiento instrumental en muchas de estas obras originales y arreglos, realza el interés y la belleza de la interpretación.

## Preamble

This second collection *Makumbé II* of Latin American Choral Repertoire for equal voices consists of original works of contemporary authors and a wide selection of choral versions of popular melodies that belong to the cultural heritage of our region.

The repertoire for equal voices is less extensive than that of mixed voices, perhaps because the number of choral groups with this scoring is also smaller.

It has been our desire to include a wide spectrum of compositions and arrangements with different levels of difficulty, so as to make this collection accessible to all types of choirs.

Some arrangements and original compositions are simple and graceful, and the possibilities of interpretation are varied and flexible. Other works, which are more complex and difficult, but of excellent quality, such as *Paisaje* by Guido Lopez Gavilán (as well as *Caracolitos Chicos* by Alberto Grau, which is not contained in this collection but is published as a separate edition, Carus 9.935), require more experienced groups and a thorough preparation on the part of the conductor.

In the course of my 30 years as Founding Director of the Cantoría Alberto Grau, the pioneer female choir of Venezuela, I have experienced and performed all of the repertoire presented in this collection. It is my hope that many choirs will enjoy singing this music and transmit to their audiences the feelings, rhythms, and colors of the Latin American soul. To help you become familiar with the music of the different regions of Latin America I have also recorded the music with Cantoría Alberto Grau, together with a group of instrumentalists who are well versed in this music.

I wish to express my deep gratitude to Flor Angélica Martínez País for her enthusiastic and dedicated engraving of the music, and to Luimar Arismendi and Albert Hernández for their preparation and performance of the complete instrumental parts.

María Guinand

### Performance with instruments

All of the instrumental accompaniment in our popular music is generally improvised by musicians who have some expertise in the different styles and rhythmic subtleties. However, in this collection for each piece we have suggested an instrumentation in accordance with the musical traditions of its region. Conductors are free to use these arrangements or create new ones, depending on the possibilities of their choirs. Nevertheless, we advise conductors to use the percussion instruments suggested for the arrangements. Also, some tunes were composed either for the introductions or the interludes, which may be modified, replaced or simply omitted by the interpreter. It is clear that the instrumental accompaniment in many of these original works and arrangements enhances the interest and success in performance.



**María Guinand**, choral conductor, university professor, and leader of many choral projects both nationally and internationally, has pursued an intense musical career. She graduated from Bristol University (England) and studied choral conducting with Alberto Grau. She continued her conducting and musical education with Helmuth Rilling, Luigi Agostoni and Johannes B. Goeschl.

Frequently invited as conductor and teacher to different events and concerts in the USA, Europe, Asia and Latin America, she has specialised in Latin-American Choral Music of the 20th and 21st centuries. She obtained the *Kulturpreis* (1998) of the InterNaciones Foundation, the *Robert Edler Preis für Chormusik* (2000) and the *Helmuth Rilling Preis* (2009).

At present, she conducts the *Schola Cantorum de Venezuela* with whom she has toured extensively and recorded many times. Always interested in new choral music, they have participated in important projects such as the

premiere, more than 45 performances and two recordings of Osvaldo Golijov's *St. Mark's Passion* (commissioned by the Internationale Bachakademie Stuttgart for the Bach commemorative year 2000); the premiere and recording of John Adams's *A Flowering Tree* (commissioned by the Vienna Festival in the Mozart's year 2006). She also conducted the premiere of Gonzalo Grau's oratorio *Aqua* (also commissioned by the Internationale Bachakademie Stuttgart) and has recorded this work with the Gächinger Kantorei and the German Youth Orchestra. She founded the *Cantoría Alberto Grau* (1976) and the *Orfeón Universitario Simón Bolívar* (1982), both highly recognized ensembles and winners of several prizes in international competitions.

1976–2009 she has been the Associated Conductor and Advisor of Choral Symphonic Performances and Activities of *El Sistema*; she teaches in the Master Degree Program for Choral Conductors at the University Simón Bolívar where she has worked as professor and conductor for 28 years. She collaborated closely with Helmuth Rilling conducting the Youth Choir of the Festivalensemble in the European Music Festival from 2001–2004, she has conducted the World Youth Choir (1998 and 2003) and has participated with her ensembles and as lecturer in several of the Simposia for Choral Music of the International Federation for Choral Music.

In recent years she has conducted concerts at opera houses and concert halls all over the world. She has led the Simón Bolívar Symphony Orchestra, the Symphony Orchestra of Venezuela, the Municipal Orchestra from Caracas, the Symphony Orchestra of Los Teques, Mérida Symphony Orchestra and the German Youth Orchestra.

As a choral promoter, she is the Artistic Director of the *Schola Cantorum of Venezuela Foundation*, and coordinates the permanent development of choral centres for children and youth of low economic resources in Venezuela and other Latin American countries in the Project *Voces Latinas a Coro* and also advises in a similar project the *Palau de la Música* (Barcelona, Spain). She also founded the *Academia Bach de Venezuela* in close relationship with the Internationale Bachakademie Stuttgart and the Academia Nacional de Canto Gregoriano. As conductor of the *Polar Foundation Choir* she has actively contributed to the development of choral music in private enterprises. She served for 12 years as Latin American Vice-President of the IFCM and she is currently Advisor to the Board. She was also a member of the International Music Council (UNESCO). She has edited various collections and editions of Latin American music, including several publications for Carus-Verlag.

# 1. He venido a despedirme

Bolivia  
Anonymous from the province of Sucre  
Choral version: Jesús Ochoa

**Liberamente**

*gliss.*  
Solo

Circa ♩ = 56

Flutes

Soprano

Mezzosoprano

Alto

Dm

*p*

*p*

*p*

C7

A7

A7

¡ah!

¡ah!

pa dap

pa

pa dap

pa

pa dap

pa dap

pa dap

pa dap

¡ah!

pa

pa dap

pa dap

Circa ♩ = 70

8

Second time only

Guitar & Charango

Bombo drum

skin wood

A7

Dm

C

Dm

A7

1.No te ex - tra-ñes mi a-ma - da si a des - ho - ras ven - go a can -  
ni-do a des-pe - dir - me por-que pre-to me voy a

pa. 1.No te ex - tra-ñes mi a-ma - da a des - ho - ras ven-go a can -  
ni-do a des-pe - me que pre-to me voy a

pa. No te ex - tra-ñes si a des - ho - ras  
te ve ni-do a des - pe -

Dm

C

Dm

A7

tar y te pí-do me per - do - nes si tu sue-ño ven-go a tur -  
ir, y te ju-ro que co - mo hom - bre mi pro - me-sa voy a cum -

tar pa dap pa dap pa dap pa dap ven-go a tur -  
ir, pa dap pa dap pa dap pa dap vo - y a cum -

ven-go a can-tar, a - diós, a - diós pues ven - go a tur -  
dir - me, a - diós, a - diós pues voy a cum -

Dm C Dm A7

*mp*

bar, y te pi-do me per - do - nes si tu sue-ño ven-go a tur-  
 plir, y te ju-ro que co - mo hom - bre mi pro - me - sa voy a cum-

bar, y te pi-do me per - do - nes si tu sue-ño ven-go a tur-  
 plir, y te ju-ro que co - mo hom - bre mi pro - me - sa voy a cum-

bar, pa dap pa dap pa dap pa dap pa dap pa dap  
 plir, pa dap pa dap pa dap pa dap pa dap pa dap

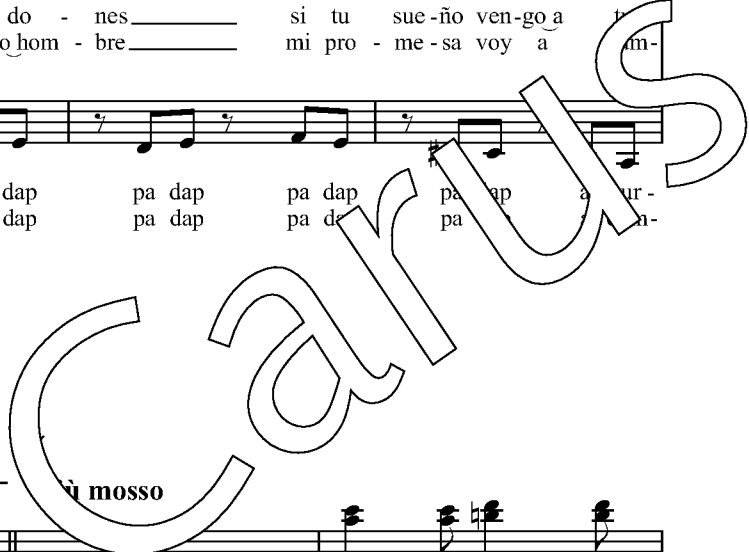

1. *allegretto mosso*

Dm A9 Dm A7

*mf*

bar. 2.He ve - plir. ¡Ah! 3.No cre-as que por mi au - sen - cia, -

*mp*

bar. 2.He ve - plir, ¡Ah! Pa dap pa dap pa dap pa dap

*mf*

bar, a tur-bar. plir. ¡Ah! 3.No cre-as que por mi au - sen - cia, -

23

A7 Dm C Dm

*mf*

yo te lle-gué a ol-vi - dar; a - diós pues a - ma - da mí - a, duér-me -

*mp*

pa dap ol - vi - dar; pa dap pa dap pa dap pa dap

*mf*

yo te lle-gué a ol - vi - dar; a - diós, a - diós, a - diós,

27

A7 Dm7 C Dm

*f*

te y vuel-ve a so - ñar, a - diós pues a - ma - da mí - a, duér-me -

*mf*

vuel-ve a so - ñar, a - diós a - ma - da mí - a, duér-me -

me pa dap pa dap pa dap pa dap

Solo

Dm C7 F Em7(b5) A7

te y vuel-ve a so - ñar.

te y vuel-ve a so - ñar.

vuel-ve a so - ñar.

36

Dm Gm7 C7 F Bbm7 Em7(b5) A7 Dm *al* 



41

**Coda** *rit.* . . . . .

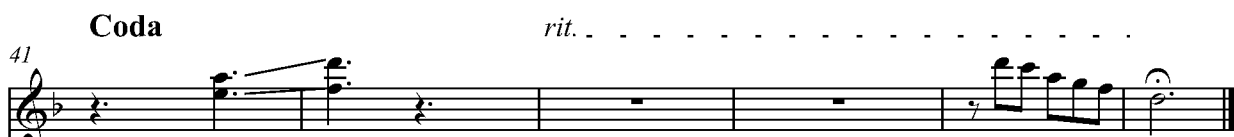

A7 Dm *p* Dm Gm9 Dm6 *f*

te y vuel-ve a so - ñar, a - ma da mí - a vuel - a - ñar.

te y vuel-ve a el-ve a - ma-da mí-a, vuel-ve a so - ñar.

ñar, vuel - ve a so - ñar.

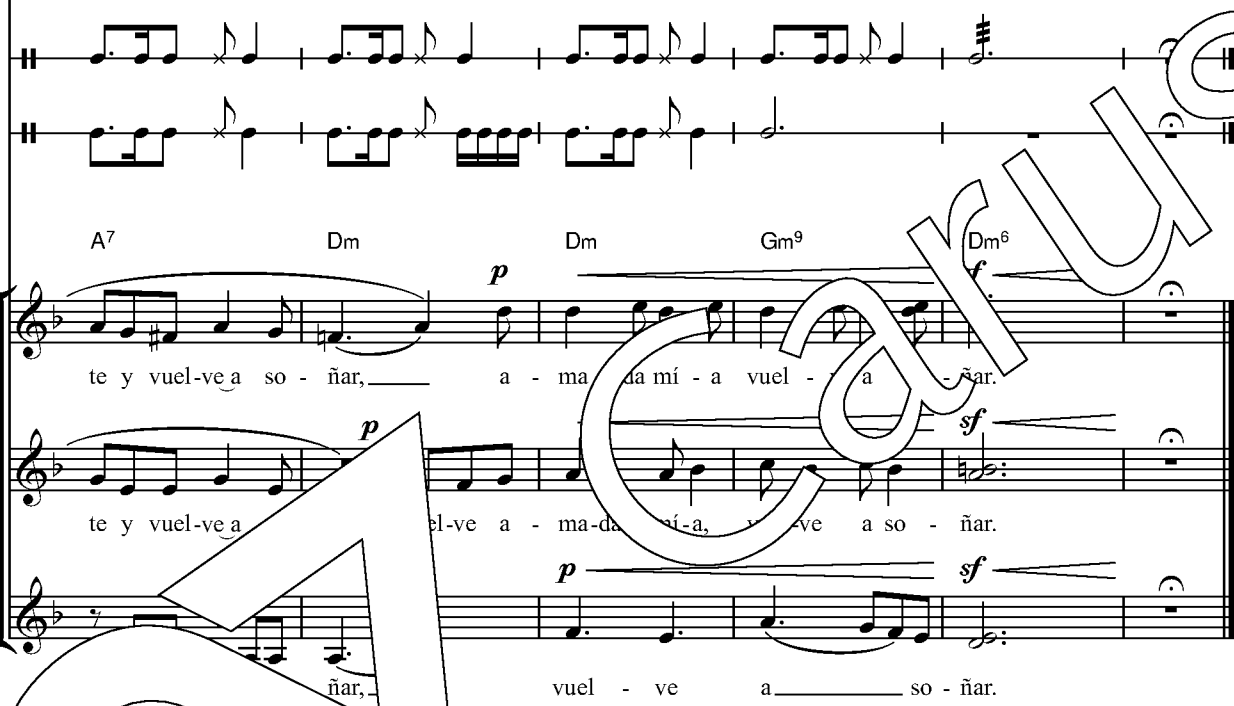
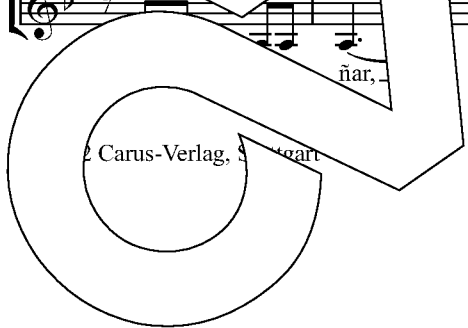
Carus-Verlag, Stuttgart

## 2. Cana-fita

To Paige F. Mathis and the Atlanta Young Singers of Callanwolde

Brazil  
Brazilian folk-song  
Choral version: Eduardo Lakschevitz

**Legato** ♩ = 102

*mp*

Soprano  
Res-ta do Só. Ca-na. Pri-mê - ra. Cô bo-ni -

*mp*

Mezzosoprano  
Res-ta. Ca-na - fi - ta. Ah. bo

*mp*

Alto  
Ah. Ca - na. i - mê - Cô bo - ni - ta.

**Dance-like** ♩ = 102

8 Drum  
(edge of the skin) w s  
(center of the skin)  
(center of the skin)

*mf*

Eu a-pran-tei ca - na na res - ta do Só. Pra nas - cê mi -

ta.

**\* Performance note:**

Although the percussion part is not fully written on the score, it is, indeed, a very important element in this piece, which is designed for treble voices and percussion. Ideally a *djembe* is the drum to be used, but a conga (or a pair of them) will do the job just as well. *Shekeres* and *Agogó* may also be added.

The main rhythmic cell is suggested in letter A, but the percussionist should be free to improvise and develop his own grooves, as in popular music playing.

13

ó: nas-ceu a ca-na - fi - ta. Eu a-pran-tei ca - na na res-ta do Só. Pra nas-ce mi -

*mp*

A - pran - tei só pra -

*mp*

A-pran-tei, pran - tei só

17

ó: nas-ceu a ca-na - fi - ta. A u - si-na pi - ta ca-na nas is - te - ra. As-su-ca de pri -

nas-cê mi - ó ca-na. A u - si-na a - pi - ta ca-na nas is - tê - ra. As-su-ca de pri -

mi - A u - si-na a - pi - ta, ca-na nas is - tê - ra. As-su-ca de pri -

21

mê - ra tem a cô bo - ni - ta. A u - si - na, ca - na de pri -

mê - ra tem a cô bo - ni - ta. A u - si - na, ca-na de pri - mê - -

mê - ra tem a cô bo - ni - ta. A u - si-na a - pi - ta, ca-na nas is - tê - ra. As-su-ca de pri -

25

**B**

*mf cresc.*

mê - ra tem a cô bo - ni - ta. Eu a - pran - tei ca - na na res - ta do Só. Pra nas - cê mi -

*mf cresc.*

- ra tem a cô bo - ni - ta. Ca - na na res - ta do Só, na res - ta do

*mf cresc.*

mê - ra tem a cô bo - ni - ta. Ca - na na res - ta, na res - ta, na res - ta do Só.

29

*mf*

ó, nas - cê mi - ó. Eu a - pran - tei ca - na na res - ta Só. Pra nas - cê mi -

*mf*

só, nas - ceu a ca - na - fi - ta. Eu a - pran - tei ca - na na res - ta Só. Pra nas - cê mi -

*mf*

A I Eu a - pran - tei ca - na na res - ta Só. Pra nas - cê mi - ó,

*mf*

A II a - pran - tei ca - na - fi - ta. Ca - na, pra nas - cê mi - ó:

*f*

Eu a ca - na - fi - ta. A u - si - na a - pi - ta, ca - na nas is - tê - ra. As - su - ca de pri -

*f*

ó: nas - ceu a ca - na - fi - ta. A u - si - na a - pi - ta, ca - na nas is - tê - ra. As - su - ca de pri -

*f*

mi - ó: nas - ceu a ca - na - fi - ta. A u - si - na a - pi - ta, ca - na nas is - tê - ra. As - su - ca de pri -

*f*

nas - ceu a ca - na - fi - ta. Ca - na. A u - si - na a - pi - ta, ca - na nas is - tê - ra. As - su - ca de pri -

mê - ra tem a cô bo - ni - ta. Ca - na! A u - si - na a - pi - ta, ca - na nas is - tê - ra. As - su - ca de pri -

mê - ra tem a cô bo - ni - ta. Ca - na! A u - si - na a - pi - ta, ca - na nas is - tê - ra. As - su - ca de pri -

A I, II

mê - ra tem a cô bo - ni - ta. Ca - na! A u - si - na a - pi - ta, ca - na nas is - tê - ra. As - su - ca de pri -

41

mê - ra tem a cô bo - ni - ta. Ca - na. A cô bo - ni - ta. Ca - na eu a - pran -

mê - ra tem a cô bo - ni - ta. Ca - na. cô bo - ni - ta. Ca - na eu a - pran - tei. \_\_\_\_\_

mê - ra tem a cô bo - ni - ta. Ca - na. cô bo - ni - ta. Ca - na eu a - pran - tei. \_\_\_\_\_

*fp*

*fp*

*fp*

comece no order suggested below, each one in one turn

(4) *mp*

Eu a - pran - tei ca - na na res - ta do Só. Pra nas - cê mi - ó: nas - ceu a ca - na - fi - ta.

(3) *mp*

Eu a - pran - tei ca - na na res - ta do Só. \_\_\_\_\_ Pra nas - cê mi - ó: \_\_\_\_\_ nas - ceu a ca - na - fi - ta.

(1) *mp*

Eu a - pran - tei ca - na na res - ta do Só, \_\_\_\_\_ nas - cê mi - ó: \_\_\_\_\_ ca - na - fi - ta.

50 **D**

Tap on the legs

Claps  
Tap on the chest

*mf* Pra nas - cê mi - ó: pran-tei  
*mf* Pra nas - cê mi - ó: pran-tei  
*mf* Pra nas - cê mi -

A I, II

53

ca - na. Nas-cê mi - ó, pran-tei  
 ca - mi - ó, pran-tei  
 mi - ó, pran-tei  
 ca - na-fi - ta. Pra nas - cê mi - ó, pran-tei.  
 ca - na-fi - ta. Pra nas - cê mi - ó, pran-tei.  
 ca - na-fi - ta. Pra nas - cê mi - ó, pran-tei.

61

*f*

A u - si - na, a u - si - na a - pi - ta, ca - na nas is - tê - ra. As - su - ca de pri -

*f*

A u - si - na, a u - si - na a - pi - ta, ca - na nas is - tê - ra. As - su - ca de pri -

*f*

A u - si - na, a u - si - na a - pi - ta, ca - na nas is - tê - ra. As - su - ca de pri -

65

mê - ra tem a cô bo - ni - ta. A u - si - na a - pi - ta ca - na nas is - tê - ra. As - su - ca de pri -

*f*

mê - ra tem a cô bo - ni - ta. Ca - na. A u - si - na a - pi - ta ca - na nas is - tê - ra. As - su - ca de pri -

mê - ra tem a cô bo - ni - ta. A u - si - na a - pi - ta ca - na nas is - tê - ra. As - su - ca de pri -

69

on the

ra. a - pran - tei ca - na, ca - na, ca - na mi - ó... Ca - na - fi - ta.

*sfz* *ff*

mê - ra. Eu a - pran - tei ca - na, ca - na, ca - na mi - ó... Ca - na - fi - ta.

*sfz* *ff*

mê - ra. Eu a - pran - tei ca - na, ca - na, ca - na mi - ó... Ca - na - fi - ta.

*sfz* *ff*

# 3. Natal

Brazil

Text and music: Ernani Aguiar

Vivaz e bem ritmado ♩ = 140

Guitar

Soprano

Mezzosoprano

Alto

4

Solo *f*

O an - jo un - ci - ou! "Je - sus nas -

Tutti

E'o ou - tro lo - go gri - tou:

Tutti *f*

E'o ou - tro lo - go gri - tou:

D6(add9) add9) D6(add9)

7

Guitar

Bass (thumb finger)

D6(add9) C6(add9) D6(add9) C6(add9) D6(add9)

Tutti *f* *mp*

ceu! "Je - sus nas - ceu!" — Um pas - tor a - dor - me - ci - do — a - cor -

"Je - sus nas - ceu! Je - sus nas - ceu!" — Um pas - tor a - dor - me - ci - do — a - cor -

"Je - sus nas - ceu!" — Um pas - tor a - dor - me - ci - do — a - cor -

Dm7 Gm7

11

Gm7 G Solo *f* Tutti *mf*

dou me - io a - tur - di - do. "¿O que? ¿O que? ¿Quem nas - ceu?" En - tão

dou me - io a - tur - di - do. En - tão

dou me - io a - tur - di - do. En - o

15

Maracas

Am7 D Am7 Dm7 *mp*

to - dos - res, - per - gun - ta - ram - com te - mo - res: "¿Quem nas - ceu, quem nas - ceu, a - on - de? ¿Quem nas - ceu, quem nas - ceu, a - on - de?" Em

pas - res, - per - gun - ta - ram - com te - mo - res: "¿Quem nas - ceu, quem nas - ceu, a - on - de? ¿Quem nas - ceu, quem nas - ceu, a - on - de?" Em

to - dos pas - to - res, - per - gun - ta - ram - com te - mo - res: "¿Quem nas - ceu, quem nas - ceu, a - on - de? ¿Quem nas - ceu, quem nas - ceu, a - on - de?" Em

19

Dm7 D *mf* *f* *mf*

ceu, quem nas - ceu, a - on - de? ¿Quem nas - ceu, quem nas - ceu, a - on - de?" Em

ceu, quem nas - ceu, a - on - de? ¿Quem nas - ceu, quem nas - ceu, a - on - de?" Em

ceu, quem nas - ceu, a - on - de? ¿Quem nas - ceu, quem nas - ceu, a - on - de?" Em

23

*cresc.* *f* *mf*

Dm7 Am7 B $\flat$ maj7 Am7

co-ro os an-jos can - ta - vam: "Em Be - lém, em Be - lém" e a - pon - ta - vam\_ a di - re - ção da ci -

co-ro os an-jos can - ta - vam: "Em Be - lém, em Be - lém" e a - pon - ta - vam\_ a di - re - ção da ci -

co-ro os an-jos can - ta - vam: "Em Be - lém, em Be - lém" e a - pon - ta - vam\_ a di - re - ção da ci -

28

*cresc.* *ff*

F7 Bm7(b5) E7 E7

da - de\_ on - de ha - vi - a nas - ci - do\_ o Rei do a - mor, da\_ da - de.

da - de\_ on - de ha - vi - a nas - ci - do\_ o Rei do a - mor, da bon - da - de.

on - de ha - vi - a nas - ci - do\_ o Rei do a - mor, da bon - da - de.

**Muito Calm**

First time  
Second time

A Bm7 E7

U - ma es - tre - la\_ bri - lhan - te, a - pa - re - ceu nes - se ins - tan - te\_

U - ma es - tre - la\_ bri - lhan - te, a - pa - re - ceu nes - se ins - tan - te\_

U - ma es - tre - la\_ bri - lhan - te, a - pa - re - ceu nes - se ins - tan - te\_

36

Bm<sup>7</sup> E<sup>7</sup> A

1. B<sup>7</sup> E<sup>7</sup>

i - lu - mi - nan - do o ca - mi - nho que le - va - va a Je - sus me - ni - ni - nho. U - ma es -

i - lu - mi - nan - do o ca - mi - nho que le - va - va a Je - sus me - ni - ni - nho. U - ma es -

i - lu - mi - nan - do o ca - mi - nho que le - va - va a Je - sus me - ni - ni - nho. U - ma es -

2. rit. . . . .

37 Bm<sup>7</sup> E<sup>7</sup> A Tempo I

va - va a Je - sus me - ni - ni - nho. *f* - la es - tra da can -

va - va a Je - sus me - ni - ni - nho. *f* Fo - ra en - tão os pas - tei - res

va - va a Je - sus me - ni - ni - nho. *f* Fo - ra en - tão os pa - to - res:

41

Guitar

Pandeiro

metal j

slap

D<sup>7</sup> C<sup>7</sup> D<sup>7</sup> C<sup>7</sup> D<sup>7</sup> C<sup>7</sup>

*mf*

tar: "¡Glo - ri - a a Deus nas al - tu - ras! ¡Va - mos Je - sus en - con - trar!

*mf*

"¡Glo - ri - a a Deus nas al - tu - ras! ¡Va - mos Je - sus en - con - trar!

*mf*

"¡Glo - ri - a a Deus nas al - tu - ras! ¡Va - mos Je - sus en - con - trar!

D7 C7 D7 E7 A7 D7 Am7

*f* ¡Glo-ri - a a Deus nas al - tu - ras! ¡Va-mos Je-sus en - con - trar!"

*f* ¡Glo-ri - a a Deus nas al - tu - ras! ¡Va-mos Je-sus en - con - trar!"

*f* ¡Glo-ri - a a Deus nas al - tu - ras! ¡Va-mos Je-sus en - con - trar!"

D7 Am7 D7 Am7 D7

*p* Be - lém Be-lém Be -

*pp* Be - lém Be-lém Be-lém Be-lém Be -

*pp* Be - lém Be -

lém Be-lém Be - lém Be-lém Be - lém Be -

lém Be-lém Be-lém Be-lém Be - lém Be-lém Be-lém Be-lém Be - lém Be-lém Be-lém Be -

lém Be - lém Be - lém Be - lém Be -

*cresc.*

58 D7 Am7 D7 Am7 D7 Am7

lém Be-lém Be - lém Be-lém Be - lém Be-lém Be

lém Be-lém Be-lém Be-lém Be - lém Be-lém Be-lém Be-lém Be - lém Be-lém Be-lém Be

lém Be - lém Be - lém Be

61 *f* D7 G Em7 Am7 D7 G Em7

E dois mil a-nos de - pois con - ti - nu - a-mos can - tan - do nos

E dois mil a-nos de - pois (tan - to tem - po) con - ti - nu - a-mos can - tan - do nos

E dois mil a-nos de - pois con - ti - nu - a-mos can - tan - do nos Na -

65 Am7 D7 Bm7 Em7 Am7 D7 Em7 Am7 D7

tais sem-pre e ao Fi-lho de Deus lou - van - do, e ao Fi-lho de Deus lou -

tan - do e ao Fi-lho de Deus lou - van - do, e ao Fi-lho de Deus lou -

is sem-pre e tan - do, e ao Fi-lho de Deus lou - van - do, e ao Fi-lho de Deus lou -

70 Am7 D7 G D7(SUS4) G

van - do, e ao Fi-lho de Deus lou - van - do, e ao Fi-lho de Deus lou - van - do!

van - do, e ao Fi-lho de Deus lou - van - do, e ao Fi-lho de Deus lou - van - do!

van - do, e ao Fi-lho de Deus lou - van - do, e ao Fi-lho de Deus lou - van - do!

# 4. Cántica N° 8

A María Cristina Sánchez

Colombia

Text and music: Luis Antonio Escobar

♩ = 158

Guitar

Soprano I

Soprano II

Mezzosoprano

Alto

6

C

A7

A7 D

*mf*

*rall.*

El de som-bre-ri-to'e ji - pa no sir - ve pa'e-na-mo

rar... El de som-bre-ri-to'e ji - pa no, no sir - ve,

El de som-bre-ri-to'e ji - pa no, no sir - ve,

El de som-bre-ri-to'e ji - pa no, no sir - ve pa'e-

*mf* Pa'e-na-mo-rar, el de som-bre-ri-to'e ji - pa no sir - ve,

17 **Moderato**

no - rar no sir - ve. Jiel - tro,

pa'e-na-mo - rar no sir - ve. Jiel - tro,

na-mo - rar no sir - ve. Y el de som-bre-ri-to'e jiel - tro,

pa'e-na-mo - rar no sir - ve. Y el de som-bre-ri-to'e jiel - tro,

6/8 3/4 6/8 5/8

C7

*f* *p*

ye - se sí a me - dio mi - rar, ye - se sí, ye - se

ye - se sí a me - dio mi - rar, ye - se sí, ye - se

ye - se sí a me - dio mi - rar, ye - se sí, ye - se

ye - se sí a me - dio mi - rar, me - dio mi - rar,

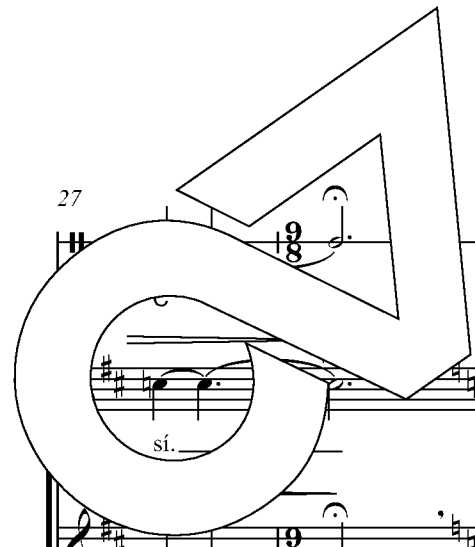

**a tempo** Guitar play on second time

27

7/8 B $\flat$ 7 E $\flat$  Cm Fm $^7$

First time *p* - Second time *f*

sí. He de dar y he de dar has - ta que de a la por -

First time *p* - Second time *f*

sí. He de dar y he de dar has - ta que de a la por -

First time *p* - Second time *f*

sí. He de dar y he de dar has - ta que de a la por -

*p* First time *p* - Second time *f*

a me - dio mi - rar. He de dar y he de dar has - ta que de a la por -

1.

B $\flat$ 7 E $\flat$  E $\flat$  D $\flat$

*p* *ff.* *mp*

jí - a, has - ta que le ha - ga chis - piar su je - ta con - tra la mí - a. \_\_\_\_\_

*p* *ff.* *mp*

jí - a, has - ta que le ha - ga chis - piar su je - ta con - tra la mí - a. \_\_\_\_\_

*p* *ff.* *mp*

jí - a, has - ta que le ha - ga chis - piar su je - ta con - tra la mí - a. \_\_\_\_\_

*p* *ff.* *mp*

jí - a, has - ta que le ha - ga chis - piar su je - ta con - tra la mí - a. \_\_\_\_\_

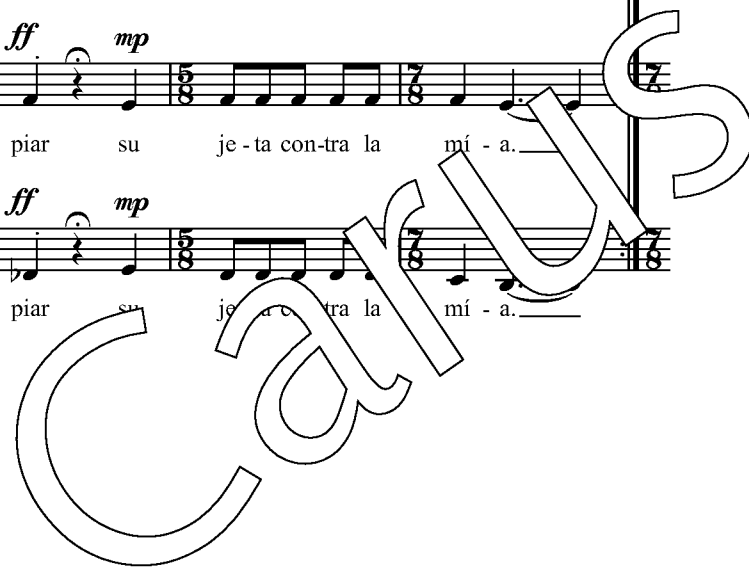

2.

36

B $\flat$ 7 E $\flat$  B $\flat$ 7 E $\flat$  Cm Fm7 B $\flat$ 7 E $\flat$  B $\flat$ 7 E $\flat$

mí - a. \_\_\_\_\_

mí - a. \_\_\_\_\_

mí - a. \_\_\_\_\_

Db Bb7 Bb7 Eb Bb7 Eb Cm Fm7

He de dar\_ y he de dar\_ has - ta que de a la por -

He de dar\_ y he de dar\_ has - ta que de a la por -

He de dar\_ y he de dar\_ has - ta que de a la

He de dar\_ y he de dar\_ has - ta que de a la por -

*rit.* - - - - -

*p* *ff.* *mp* *ff.* *mp* *p* *ff.* *mp* *p* *ff.* *mp*

jí - a, na - ga chis - piar su je - ta con - tra la mí - a.

has - ta que le ha - ga chis - piar su je - ta con - tra la mí - a.

jí - a, has - ta que le ha - ga chis - piar su je - ta con - tra la mí - a.

jí - a, has - ta que le ha - ga chis - piar su je - ta con - tra la mí - a.

# 5. El torito

Typical dance from Costa Rica  
Choral version: Pedro Antonio Silva

**Intro** **Maestoso** ♩ = 84

Trumpet in C

Snare Drum  
Drum

Soprano *mf* El to-ro Si-ma,

Mezzosoprano

Alto *mf* Que co-ja el - ro,

**Allegretto** ♩ = 100

Mari-pa

Güira

Snare Drum  
Drum

Guitar

Bass Guitar

F C7 F

6 *f* *mf*

el to - ro. É - cha - me e - se to - ro pin - to, hi -

*mf* *f* *mf*

Que te co - ja el to - ro. É - cha - me el to - ro de

*f* *mf*

el to - ro. E - se to - ro

11

C7 F6 F6 Gm7 C7

*simile*

jo de la va - ca mo - ra, pa - ra sa - car - te u - na suer - te de - lan - te de mi se -

va - ca mo - ra, con u - na suer - te de mi se -

*simile*

pin - to de la va - ca mo - ra, pa - ra e - char - te suer -

16

F F C7 F6 Gm7 Am

*p*

ño - ra. ¡ay! el to - ¡ay! el

*f*

ño - ra. to - ro me ma - ta - re, no me en - tie - rren en sa - gra - do, en -

*simile*

pa - to - ro me ma - ta - re no me en - tie - rren en sa - gra - do, en -

Gm C7 F F6

to - ro, ¡ay! el to - ro, to - ro si.

tié - rren - me en cam - po a - fue - ra don - de me pi - se el ga - na - do.

*mf staccato*

tié - rren me en cam - po a - fue - ra don - de me pi - se el ga - na - do. Que te co - ja el

26 Trumpets

*Gm<sup>6</sup>* *F* *Dm<sup>7</sup>* *Gm<sup>6</sup>*  
*p* ¡Ay! el to - ro, vie - ne el to - ro, ¡ay! el  
*p* ¡Ay! el to - ro, vie - ne el to - ro, ¡ay! el  
 to - ro Si-mo-na, que te co-ja el to - ro Mar-ce - la, que te co-ja el to - ro Si-mo-

31  
*C<sup>7</sup>* *F<sup>6</sup>* *C<sup>7</sup>* *G* *C<sup>7</sup>*  
 to - ro si, ¡ay! to - ro  
 to - ro Si-mo-na, el  
 to - ro e - la, que te co-ja el to - ro Si-mo-na, que te co-ja el  
 si, vie - ne el to - ro no. No  
 to - ro Mar-ce - la, el to - ro Si-mo-na el to - ro no. De  
 to - ro Mar-ce - la, que te co-ja el to - ro Si-mo - na, que te co-ja el to - ro Mar-ce - la.

Marimba

F C7 F C7 F6 F6 Bb

*mf* *simile*

mu-rió de ca - len - tu - ra ni de do-lor de cos - ta - do, mu - rió de u-na cor -

ca - len - tu - ra ni de cos - ta - do, u - na cor -

No de ca - len - tu - ra, do - lor de cos - ta do,

Gm7 C7 D7 D7

na - da que le dió el - ro pin - ta do.

na - da pin - ta - do.

na a se mu-rió.

Em7 Am D7 G G D7 G6 *mf*

¡Ay! el

A - llá en a-quel rin - cón pin -

En a-quel rin - cón pin -

59 D7 G Em7 Am D7

to - ro, ¡ay! el to - ro, ay! el to - ro,

ta - do de co - lo - ra - do, a - lli es - tán las cin - co le - tras don - de mu rió el des - di -

ta - do de co - lo - ra - do, a - lli es - tán las cin - co le - tras don - de mu - rió el des - di -

*simile*

*simile*

64 Trumpets

Marimba

G G6 D7 D7 G

to - ro si. ¡Ay! el to ro, vie - ne el

cha - do. ¡Ay! el - ro, vie - ne el

Que te el to - ro Si - mo - na, que te co - ja el to - ro Mar - ce - la,

G6 Am6 D7 G G6

to - ro, ¡ay! el to - ro si,

to - ro, ¡ay! el to - ro si, el

que te co - ja el to - ro Si - mo - na, que te co - ja el to - ro Mar - ce - la, que te co - ja el

*p*

*p*

*gliss.*

*gliss.*

*mf*

*f*

Am<sup>6</sup> D<sup>7</sup> G Em<sup>7</sup> Am<sup>6</sup>

*mf*

¡ay! el to - ro no, \_\_\_\_\_ vie - ne el  
 to - ro Si - mo - na, \_\_\_\_\_ el to - ro Mar - ce - la, \_\_\_\_\_ el to - ro Si - mo - na, el  
 to - ro Si - mo - na, que te co - ja el to - ro Mar - ce - la, que te co - ja el to - ro Si - mo - na,

Güiro  
 Snare Drum  
 Guitar  
 Bass Guitar

D<sup>9</sup> G<sup>6</sup> D<sup>7</sup> G

*f* *ff*

to - ro, el to - ro si... ¡To - ri - to! ¡Yo - lé!  
*cresc.* *f* *ff*  
 to - ro, el to - ro, el to - ro si... ¡To - ri - to! ¡Yo - lé!  
*cresc.* *f* *ff*  
 que te co - ja el to - ro, el to - ro si... ¡To - ri - to! ¡Yo - lé!

# 6. Paisaje

Cuba

Text: Felipe González

Music: Guido López Gavilán

*poco rit.* **Allegretto, ligero**

Solo  
Pri ki tin kin kin kin

Soprano  
*pp* E hue (b.c.) *poco rit.* *p* Pri ki tin kin cum blín pri ki

Mezzosoprano  
*pp* E hue (b.c.) *poco rit.* *p* Pri ki tin kin cum blín

Alto  
*pp* E hue (b.c.) *poco rit.* *p* Pri ki tin kin cum blín

4 *poco rit.* *p* a tempo *cresc.*

pri ki tin ble - *poco rit.* blén *p* ki tin tin kin cum blín pri ki ti ki

blén *poco rit.* blén *p* 3 pri ki tin pri ki tin kin cum blín

blén *poco rit.* blén *p* pri ki tin kin cum blín

9 *poco rit.* **vivo**

tin kin kin blé - en cun cum blín cun cum blén cun cum blán pri ki tin cum ban ba

*poco rit. cresc.* *f* pri ki tin blén cum blín cum blén blbl - án

*poco rit. cresc.* *f* pri ki tin blén cum blín cum blén blbl - án

**A**

**Libre**

14

hue - y La lu - na es u - na pi - ña - ta re - par - ti - da pa - ra to -

La lu - na es u - na pi - ña - ta re - par - ti - da pa - ra to -

La lu - na es u - na pi - ña - ta re - par - ti - da pa - ra -

*poco f* *mf*

**B**

19

pri ki ti tin kin kin kin

dos (b.c.) pri ki n kin cum blán pri kin kin blé - en cun cum

dos (b.c.) pri ki pri ki tin kin cum blán pri ki tín blén

dos (b.c.) pri ki tin kin cum blán pri ki tín blén

*rit.* *a tempo* *p* *f* *vivo*

**C**

23

blín cun cum blén cun cum blán pri ki tin cum ban ba La lu - na es u - na pi - ña - ta

cum blín cum blén blbl - án La lu - na es u - na pi - ña - ta

cum blín cum blén blbl - án La lu - na es u - na pi - ña - ta

*rit.* *f*

*rit.*  
pri ki ti ki tin kin kin kin

*mf* *cresc.* *rit.*  
re-par-ti - da pa-ra to - dos que en - tre mon - ta - ñas y lo - dos

*mf* *cresc.* *rit.*  
re-par-ti - da pa-ra to - dos que en - tre mon - ta - ñas y lo - dos

*mf* *cresc.* *rit.*  
re-par-ti - da pa-ra to - dos que en - tre mon - ta - ñas y lo - dos

*rit.*  
pri ki ti tin kin in krrrin

**tranquilo**  
*ten.* *p* *rit.* **tempo tranquilo**  
vier - te sus lu-ces de pla ta (b.c.) pri ki tin kin cum blén pri ki

*ten.* *p* *rit.* *pp*  
vier - te sus lu-ces de pla ta (b.c.) blén blén

*p* *rit.* *pp*  
vier - te sus lu-ces de pla ta (b.c.) blén blén

*p* **a tempo, ligero** *cresc.*  
tin kin cum blán ba huey pri ki ti tin kin cum blán pra ka tan blín blín cum blén

*poco rit.* *p* *cresc.*  
cum blín blán ba huey pri ki ti prin pri ki tin pri ki tin kin cum blín blén

*poco rit.* *p* *cresc.*  
cum blín blán ba huey pri ki ti cum blín cum blín blén

**E**

38

*poco accel.*

**a tempo**

*p*

*mf*

*poco accel.*

*p*

*mf*

*poco accel.*

*p*

*mf*

41

*cresc.*

*cresc.*

*cresc.*

pri ki ti ki

y el ri - o es u - na cor - ba - ta en - tre la pal - ma y el lla - no

y el ri - o es u - na cor - ba - ta en - tre la pal - ma y el lla - no

y el ri - o es u - na cor - ba - ta en - tre la pal - ma y el lla - no

*rit.* **p** *rit.*  
 ti ki ti ki ti ki ti tin tin cun blén pri ki ti tin kin cun blén

*rit.* **più p** *rit.* **pp** **f**  
 (b.c.) cun blén y el rí-o es u-na cor-ba - ta

*rit.* **più p** *rit.* **pp** **f**  
 (b.c.) cun blén y el rí-o es u-na cor-ba - ta

*rit.* **più p** *rit.* **pp** **f**  
 (b.c.) cun blén y el rí-o es u-na cor-ba - ta

**G**

**amplio\***

48 **più f** **uy inte**  
 en-tre la pal-ma y el lla - no, y el cam - si - no cu - ba - no lle - va en su her - mo - so a - ta -

**più f**  
 en-tre la pal-ma y el cam - pe - si - no cu - ba - no lle - va en su her - mo - so a - ta -

**più f**  
 en-tre la pal-ma y el cam - pe - si - no cu - ba - no lle - va en su her - mo - so a - ta -

**mp**  
 vi - o to - da el al - ma del bo - hí - o he - cho de pal - mas y gua -

*ten.* **ff** **mp**  
 vi - o to - da el al - ma del bo - hí - o he - cho de pal - mas y gua -

*ten.* **ff** **mp**  
 vi - o to - da el al - ma del bo - hí - o he - cho de pal - mas y gua -

\* broad

**H**

*rit.*

pri ki ti tin kin kin kin

**a tempo, tranquilo**

*p* *rit.* *p*

no (b.c.) pri ki tin kin cun blín pri ki tin kin cun blán prin pri ki tin pri ki tin cun blín \_

*p* *rit.* *p*

no (b.c.) blín blín blín blán prin pri ki tin pri ki tin cun blín \_

*p* *rit.* *p*

no (b.c.) blín blín blín blán prin pri ki tin pri ki tin cun blín \_

**I**

**muy rítmico**

*mf*

57

prin pri ki tin pri ki tin cun blán \_ bin b blebl blén blín pri ki tin p in kin blibl bin blebl ben

*mf*

prin pri ki tin cun blán bin b blibl blebl blén blín pri ki tin pri ki chin kin blibl bin blebl ben

*mf* *p*

prin pri ki tin p cun cun blén blén blín cun blín cun blín blebl ben

*poco rit.*

**a tempo**

blán blabl ban bin blibl blebl ben blín pri ki ti ki ti ki ti ki tin kin blibl bin blebl ben

*poco rit.*

blán blabl ban bin blibl blebl ben blín pri ki ti ki ti ki ti ki tin kin blibl bin blebl ben

*poco rit.*

blán blabl ban cun cun blén blén blín pri ki ti ki ti ki ti ki tin kin cun blín blén ben

*mp* *rit.*  
 cun cun blín cun cun blén blbl blán ba

*pp* *rit.* *pp*  
 blán blán pra ca chán blbl bln (b.c.)

*pp* *rit.* *pp*  
 blán blán pra ca chán blbl bln (b.c.)

*pp* *rit.* *pp*  
 blán blán pra ca chán blbl bln (b.c.)

**J**

**a tempo, poco più vivo**

68 *p ligero* *f* *mf*  
 cun blín blín blibl blán pra ca chán cun blín blín blibl blí ki tin pri ki chin kin

*p ligero* *f* *mf*  
 cun blí pra ca chán cun blín blín blibl blín pri ki tin pri ki chin kin

*f* *mf*  
 cun blín blín pra ca chán cun blín blín blibl blín pri ki tin pri ki chin kin

**K**

72 *cresc.* *poco rit.* *f*  
 cun blín kin blín blblín blín blbl blín blbl blín bin cun blín kin blín blblín blblán

*cresc.* *poco rit.* *f*  
 blín kin blín kin blín blbl blín blbl blín bin blín kin blín kin blblán

*cresc.* *poco rit.* *f*  
 cun cun blín blín blblín cun blín cun cun blín blblán

76 *poco accel.*  
**p** *cresc.*

*cede* *rit.* **p** *perd.*

prin pri ki prin pri ki prin pri ki prin pri ki ti ki ti ki ti ki ti ki ti ki ti ki tin prin kin cun blén

*poco accel.*  
**p** *cresc.*

*cede* *rit.* **p** *perd.*

(b.c.) prin pri ki prin pri ki prin pri ki ti ki ti ki ti ki ti ki ti ki ti ki tin cun blén

*poco accel.*  
**p** *cresc.*

*cede* *rit.* **p** *perd.*

(b.c.) prin pri ki ti ki ti ki ti ki ti ki tin cun blén

**L** **amplio**

78 **pp** *più f sempre* **vivo**

La lu-na es u-na pi-ña - ta re - par - ti - da pa - ra do - blin blin blin ben

**pp** *più f sempre* **f**

La lu-na es u-na pi-ña re - par - ti - da pa - ra - dos blin blin blin ben

**pp** *più f sempre* **f**

u-na pi-ña re - par - ti - da pa - ra to - dos blin blin blin ben

**deciso** **ff** *p <> ppp*

blin blin blin ben blán ban pra ca chán pra ca chán blin ben.

**ff** *p <> ppp*

blin blin blin ben blán ban pra ca chán pra ca chán blin ben.

**ff** *p <> ppp*

blin blin blin ben blán ban pra ca chán pra ca chán blin ben.

# 7. La rosa y el clavel

Cueca

Chile

Folk song

Choral version: Jesús A. Hernández

Allegro ♩ = 116

Flute I, II

Guitar & Charango

Bombo Drum

Soprano

Mezzosoprano

Alto

wood skin

F#m E D7 C#7 Bm7 E7 A7

5

Flutes may improvise throughout

G#m(usb) C#7 F#m D7 C#7 F#m *mf* F#m

La ro - sa, \_\_\_\_\_ la ro -

*mp*

La ro - sa, \_\_\_\_\_ la ro -

*mp*

La ro - sa, la ro -

sa con el cla-vel, \_\_\_\_\_ mi vi - da hi - cie - ron, \_\_\_\_\_ hi - cie -  
 sa con el cla-vel, \_\_\_\_\_ el cla-vel, \_\_\_\_\_ el cla-vel, \_\_\_\_\_ mi da,  
 sa con el cla-vel, \_\_\_\_\_ el cla - vel, \_\_\_\_\_ mi vi - da, \_\_\_\_\_ vi - da,

ron un ju - ra - men \_\_\_\_\_ mi vi - da hi - cie - ron, \_\_\_\_\_ hi - cie - ron un ju - ra - men -  
 mi vi - da, mi vi - da hi - cie - ron, \_\_\_\_\_ hi - cie - ron un ju - ra - men -  
 ju - ra \_\_\_\_\_ mi vi - da hi - cie - ron, hi - cie - ron, hi - cie - ron un ju - ra - men -

to, \_\_\_\_\_ mi vi - da, mi vi - da, de tes - ti - go, \_\_\_\_\_  
 to, ay, ay, ay, \_\_\_\_\_ mi vi - da, mi vi - da, de tes - ti - go mi vi - da,  
 to, \_\_\_\_\_ mi vi - da y pu - sie - ron, y pu - sie - ron de tes - ti - go, \_\_\_\_\_ mi

25 C#7 F#m F#m E D#6 C#7

*mf* *f*

mi vi - da, un jaz - mín, a un jaz - mín y a un pen - sa - mien - to. Mi

*mf*

mi vi - da, un jaz - mín, a un jaz - mín y a un pen - sa - mien - to, pen - sa - mien - to.

*mf*

vi - da a un jaz - mín, a un jaz - mín y a un pen - sa - mien - to.

**B** 29 C#7 F#m F#m E D C#7 C#7 F#m

*mp* *mf*

vi - da y la ro - sa, ay, ay, ay, ti - con ro - sas, -

*mp* *f* *mp*

Ay, ay, ro - sa con el cl... ay, ay, ay, ay,

*mp* *mf*

ay, ay, ay, ay, el cla - vel, ay, ay, ay, ay,

33 F#m C#7 C#7 F#m F#m E D

*mf* *mp*

ay, ay, ay, ay, ay, tí - ra - me con vio - le - tas, ay, ay, ay,

*f*

ay, ay, ay, ay, ay, ay, ay, ay, ay, ay, que son más fi -

*mp*

ay, que tie - ne es - pi - nas, ay, ay, ay, ay, ay, ay, ay, ay, ay,

C#7 C#7 D F#m E D C#7

*mf*

ay, no me ti-res con ro-sas, ay, ay, ay que tie-ne es-pi - nas. —

*mf*

nas, ay, ay, ay, ay ay ay, ay, ay, ay que tie-ne es-pi - nas. —

*mf*

ay, ay, más fi-nas, ay, ay, ay, ay ay ay, ay, ay, ay que tie-ne es-pi - nas. —

Bm7 E7 G7 G6 G#m7 C#7 F#m D

**C**

C#7(SUS4) C#7 *mf* C# C#7 F#m

Que son más fi-nas si, ay, ay,

*mf*

Que son más fi-nas si, ay, ay,

*mf*

Que son más fi-nas si, ay, ay,

55

F#m Bm C#7 C#7 F#m F#m E D#6

ay, ro-sa con da - lia, don - de i - rá mi ne - gri - to, ay, ay, ay, que yo no va -

ay, ro-sa con da - lia, ay, ay, ay, don - de i - rá mi ne - gri - to, ay, ay, ay, que yo no va -

ay, ro-sa con da - lia, don - de i - rá mi ne - gri - to ay, ay, ay, ay, ay, ay, que yo no va -

60

C#7 C#7 G F#m F#m E D# C#7

*p sub.*

ya, an - da ro-sa con da - lia, ay, ay, ay, yo no va - ya, yo no

*p sub.* *p*

ya, ay, ay, ay, an - da ro-sa con da - lia, ay, ay, ay, que yo no va - ya, yo no

an - da - sa con da - lia, ay, ay, ay, ay, ay, ay, que yo no va - ya,

*accel. e cresc.*

*mf* *F#* *F#* *F#*

va-ya, yo no va-ya, yo no va-ya, yo no va-ya.

*mf*

va-ya, yo no va-ya, yo no va-ya, yo no va-ya, yo no va-ya.

*p* *mf*

yo no va-ya, yo no va-ya, ay yo no va-ya, ay yo no va-ya, no va-ya.

# 8. El barreño

Guatemala  
Anonymous traditional  
Choral version: Alberto Grau

**Allegretto** ♩ = ca. 132

Marimba I

Marimba II

Guitar

Maracas

Drum

Soprano

Mezzosoprano

Alto

Marimbas may continue improvising  
or doubling the melodic line

Gm<sup>7</sup> C<sup>7</sup> F

*mf*

La la rai lai lai lai lai lai

*mf*

La la rai lai lai lai lai lai

*mf*

La ra lai

11

C7 F F Gm C7

la la rai lai lai lai lai lai la la rai lai lai lai la la rai lai lai lai...  
 la la rai lai lai lai lai lai la la rai lai lai lai la la rai lai lai lai...  
 la ra lai la ra lai la ra lai la ra lai

16

Guitar Maracas Drum

stacc. sempre mf F6 Gm

1. De los... (2.) mue... De los... (2.) mue... lai...  
 ...lli - tos que me tra - jo us - ted nin - gu - no me  
 ...ra quien me en - te - rra - rá só - lo las Her -  
 ...lli - tos que me tra - jo us - ted nin - gu - no me  
 ...ra quien me en - te - rra - rá só - lo las Her -  
 ...lli - tos que me tra - jo us - ted nin - gu - no me  
 ...ra quien me en - te - rra - rá só - lo las Her -

19

F F C

gus - ta, só - lo el que ma - té. Há - ga - se pa' - ca, há - ga - se pa' - llá, que mi ca - ba -  
 ma - nas de la Ca - ri - dad.  
 gus - ta, só - lo el que ma - té. Há - ga - se pa' - ca, há - ga - se pa' - llá, que mi ca - ba -  
 ma - nas de la Ca - ri - dad.  
 gus - ta, só - lo el que ma - té. Há - ga - se pa' - ca, há - ga - se pa' - llá, que mi ca - ba -  
 ma - nas de la Ca - ri - dad.

23

1. Gm C F 2. Gm C F

lli - to lo a-tro - pe - lla - rá. Há - ga - se pa' lli - to lo a-tro - pe - lla - rá.

lli - to lo a-tro - pe - lla - rá. Há - ga - se pa' lli - to lo a-tro - pe - lla - rá, lo a-tro - pe - lla - rá.

lli - to lo a-tro - pe - lla - rá. Há - ga - se pa' lli - to lo a-tro - pe - lla - rá, lo a-tro - pe - lla - rá

25

F Gm C

*f*

1. A - llá vie - ne un le - che - ri - to con sá - can - ro de pla - ta  
 2. Cuan - do es - te bá - rre - ño vi - no no sa - bí - an bai - lar, \_\_\_\_\_

*f*

1. A - llá vie - ne ri - to con sá - can - ta - ro de pla - ta  
 2. Cuan - do es - te vi - no no sa - bí - an bai - lar, \_\_\_\_\_

*f*

1. A - llá vie - ne pla - ta  
 2. Vi - no ba - i - lar

Last time to Coda

Gm C F

1.

y la ni - ña le res - pon - de e - sa le - che a mi me ma - ta.  
 ho - ra que to - dos lo sa - ben, no lo de - jan des - can - sar. \_\_\_\_\_

y la ni - ña le res - pon - de e - sa le - che a mi me ma - ta.  
 ho - ra que to - dos lo sa - ben, no lo de - jan des - can - sar. \_\_\_\_\_

res - pon - de me \_\_\_\_\_ ma - ta.  
 lo \_\_\_\_\_ sa - ben des - can - sar. \_\_\_\_\_

32 **Coda**

2. *al*  $\frac{8}{8}$  F F Gm Gm C

ma-ta. 2. Cuan - do yo me sar. ¡Ay! ba-rre-ño si, ¡ay! ba-rre-ño no, ¡ay! ba-rre-ño due-ño de mi co-ra-

ma-ta. 2. Cuan - do yo me sar. ¡Ay! ba-rre-ño si, ¡ay! ba-rre-ño no, ¡ay! ba-rre-ño due-ño de mi co-ra-

ma-ta. 2. Cuan - do yo me ¡Ay! ba-rre-ño si, ¡ay! ba-rre-ño no, ¡ay! ba-rre-ño due-ño de mi co-ra-

37

Marimba I | 2.

Marimba II

Guitar

Maracas

F Gm F

*f*

zón, ¡ay! ba-rre-ño due-ño de mi co - ra - zón.

zón, ¡ay! ba-rre-ño due-ño de mi co - ra - zón.

zón, ¡ay! ba-rre-ño due-ño de mi co - ra - zón.

# 9. La golondrina

Mexico  
Text and music: Narciso Serradell  
Choral version: Alberto Grau

Andantino ♩ = ca. 54

Soprano *mf sempre legato* D<sup>6</sup>(add9) Em<sup>7</sup> A<sup>9</sup>  
A dón-de i - rá la go - lon - dri - na bus-can-do a -

Mezzosoprano *mf sempre legato*  
A dón-de i - rá la go - lon - dri - na bus-c do a -

Alto

Più mosso ♩ = ca. 66

3 Guitar \* *mf* A<sup>7</sup> D Em<sup>7</sup> A<sup>7</sup> *simile*

bri - go (b.c.) de i - rá loz y fa - ti - ga - da, la go - lon - *simile*

go (b.c.) a de i - rá ve - loz y fa - ti - ga - da, la go - lon - *simile*

(b.c.) a dón - de fa - ti - ga - da i - rá, la go - lon - *mf*

dri - na que de a - hí se va; oh! si en el cie - lo se ha - lla - rá ex - tra -

dri - na que de a - hí se va; oh! si en el cie - lo se ha - lla - rá ex - tra -

dri - na que de a - hí se va, se va; oh! si en el cie - lo se ha - lla - rá ex - tra -

D A<sup>7</sup> D D<sup>7</sup>

\* Second guitar may improvise on the melody and harmonies

*poco allarg.*

9

G D D<sup>7</sup> A<sup>7</sup> D *f legato*

via - - da bus-can-do a - bri - go y no lo en-con-tra - rá. Jun-to a mi

via - - da bus-can-do a - bri - go y no lo en-con-tra - rá. Jun-to a mi

via - - da bus-can-do a - bri - go no lo en-con - tra - rá.

*a tempo*

12

A<sup>7</sup> D Em<sup>7</sup> A<sup>7</sup>

pe - cho le pon - do en don-de pue - da la es-ta - ción pa -

pe - cho le pon - do en don-de pue - da la es-ta - ción pa -

*f legato*

A mi pe-cho ni - do don-de pue - da la es-ta - ción pa -

D *mp* D *mp* D<sup>7</sup> G

sar, tam-bién yo es - toy en la re - gión per - di - da ¡oh! cie-lo

sar, tam-bién yo es - toy en la re - gión per - di - da ¡oh! cie-lo

sar, tam-bién yo es - toy en la re - gión per - di - da ¡oh! cie-lo

18

Mandolin

*poco allarg.*

**a tempo**

san - to sin po-der vo - lar.

san - to sin po-der vo - lar, po-der vo-lar.

san - to sin po-der vo-lar.

D D° A7 D B B7

21

**a tempo**

Jun-to a mi

F#7 B7 *mf*

Guitar (basic rhythm) – Mandolin may also improvise on harmonies

# 10. Mariposa candorosa

Danzón

Mexico  
Text: Rosa Carreto  
Music: José Antonio Rincón

Allegretto ♩ = 80

The musical score is arranged in a multi-staff format. The top section includes instrumental parts for Flute, Güiro, Clave, Bongo, and Guitar. The Flute part begins with a dynamic marking of *f*. The Güiro, Clave, and Bongo parts provide a rhythmic accompaniment. The Guitar part includes chord markings: D, E7, D, and D7. Below these are the vocal staves for Soprano, Mezzosoprano, and Alto. A large, stylized watermark 'CARUS' is overlaid across the vocal staves. The bottom section of the score shows the vocal melody with lyrics: 'Pa ra ra pa pa ra ra pa'. The lyrics are repeated on two lines. The first line of lyrics is accompanied by a dynamic marking of *mf* and a slur. The second line also has a *mf* marking and a slur. The score concludes with a double bar line and repeat dots.

Em7 *mf* A7 D D D7 G

Ma - ri - po - sa can - do - ro - sa ven a - le - gre

pa ra ra\_\_ pa ra ra pa pa ra ra pa pa ra ra\_\_ pa ra ra pa pa ra ra pa pa ra ra\_\_ a - le - gre

*ff* *ff*

pa ra ra\_\_ Hey! pa ra ra pa pa ra ra pa pa ra ra\_\_ Hey! pa ra ra pa pa ra ra pa pa ra ra\_\_ a - le - gre

1. 2.  $\$$

G D D D D

can - ta mi can - ción. ción. Tra - vie - s - na - po - sa de

*mf*

can - ta mi ca ción. vie - sa u - na ma - ri - po - sa de

*mp*

sa. ción, can - do - ro - sa Ma - ri - po -

A A A7 A7

be - lli - si - mo co - lor de u - na ro - sa\_\_ so - bre el cá - liz el rau - do vue - lo pa -

be - lli - si - mo co - lor de u - na ro - sa\_\_ so - bre el cá - liz el rau - do vue - lo pa -

3 3 3

si - ta de be - lli - si - mo co - lor su rau - do vue - lo pa -

*tr*

D D7 G G7 E7 A

ró. Des - pués hu - yó \_ la in - cons - tan - te que - dó en su ta - llo la flor... Tu a -

ró. Des - pués hu - yó \_ la in - cons - tan - te que - dó en su ta - llo la flor... Tu a -

ró so - bre \_ u - na flor. E - sa flor \_ en - to - nó su más be

A7 F#m7 D A7 D Em A7

mor fue la \_ ma - ri - po - sa, la ro - sa mi \_ co - ra - zón, tu a - mor fue la \_ ma - ri -

mor fue la \_ sa, la ro - sa mi \_ co - ra - zón, tu a - mor fue la \_ ma - ri -

ri - po - sa es mi co - ra - zón, la ma - ri -

A

A D D D E7

po - sa la \_ ro - sa, ro - sa mi \_ co - ra - zón. *p* Rá - pi - do el vien - to de un

po - sa, la ro - sa mi \_ co - ra - zón. *p* Rá - pi - do el vien - to de un

po - sa mi co - ra - zón. *f* En un her - mo - so

Em7 A7 Em7 A7 D D

la - go la su-per - fi - cie be - só,

la - go la su-per - fi - cie be - só,

la - go el sol bri - lla - ba y el cen-zon - tle fe - liz de a - mor can - ta - b

D Bm7 A7 A7 Em7 A7

*mp* ha - la - gos y ca - cías el vien - es brin - da - ba.

*p* ha - la - gán to ca - ri - cías de a - mor.

*p* ha - la - gán to con sus ca - ri - cías de a - mor.

Last time to Coda

*mp* D D7 G E7 A *mf*

Hu - yó el cé - fi - ro li - ge - ro, el la - go no se mo - vió... tu a -

*mp* Hu - yó el cé - fi - ro li - ge - ro, el la - go no se mo - vió... tu a -

*mp* El cé - fi - ro li - ge - ro, el la - go no se mo - vió...

D Em7 A7

*f* D D E7

mor e-ra el vien-te - ci-llo y el la-go mi-co-ra - zón.

mor e-ra el vien-te - ci-llo y el la-go mi-co-ra - zón.

tu a-mor mi vi-da y mi co-ra - zón.

A7 D G G#o D A7 D *mf*

al *f*

Tra- *mf*

Tra-

## Coda

D Em Em7 A7 D

*f*

vió... tu a-mor e-ra el vien-te - ci-llo y el la-go mi-co-ra - zón. ¡Ah!

*mf* *f*

vió... tu a-mor e-ra el vien-te - ci-llo y el la-go mi-co-ra - zón. ¡Ah!

vió... tu a-mor mi vi-da y mi co-ra - zón. ¡Ah!

# 11. Aniceto Rondón

## Contradanza

A la Cantoría Alberto Grau con todo mi cariño

Venezuela

Anonymous traditional from Zulia State

Choral version: Jesús Ochoa

**Lento** ♩ = 60

Soprano I  
Es - ta es, es - ta es la

Soprano II  
¿Qué se - rá?

Alto I  
Si se - ñor, ta es la

Alto II  
Es - ta es, es la

**tempo**

**Allegro** ♩ = 80

Metalic Güira

Maracas

Drum wood

Castro

F F D<sup>7</sup> Gm<sup>6</sup>

*mf* gai - ta de A - ni - ce - to Ron - dón, hom - bre cul - to de cien - cia mu - si - cal, to - do a -

*mf* A - ni - ce - to Ron - dón, es la gai - ta cien - cia mu - si - cal

*mf* gai - ta de A - ni - ce - to Ron - dón, es la gai - ta hom - bre cul - to mu - si - cal

*mf* gai - ta de A - ni - ce - to Ron - dón hom - bre cul - to mu - si - cal

11

Gm<sup>6</sup> C<sup>7</sup> Gm<sup>7</sup> C<sup>7</sup> 1. F<sup>6</sup>

quel que la se-pa can - tar ven-ga pres-to pa-ra es-te pa-ran - dón. Es-ta es la

a - quel se-pa can-tar ven-ga pres-to pa-ra es-te pa-ran - dón. Es-ta es

a - quel se-pa can-tar ven-ga pres-to pa-ra es-te pa-ran - dón. Es-ta es la

a - quel se-pa can-tar ven-ga pres-to pa-ra es-te pa-ran - dón. Es-ta

14

2. F<sup>6</sup> A<sup>7</sup> Dm A<sup>7</sup> Dm

dón. ¡Uh! ¡uh!

dón, pa - rran - dón. ¡Uh! es-ta es la ta mu - si

dón, pa - rra ¡Uh! es la gai - ta mu - si

En la en - ta - na po - ni - an - ban - de - ra al que - le to -

ta ai - ta - ve - te - ra - na - con rit - mo de - con - tra -

Gm<sup>6</sup> C<sup>7</sup> *f* C<sup>7</sup> *f*

la la rai la ¡ay! ca-ram - ba, has - ta a-ma-ne-er el

muy mu-si-cal la rai la ¡ay! ca-ram - ba. al Zu - lia can-ta con

muy mu-si-cal ha - cer la fies-ta y pa - ga ¡ay! ca-ram - ba la rai

el Sa - la - di - llo a la u - san - za ¡ay! ca-ram - ba

ca - ba - la rai la ¡ay! ca-ram - ba la rai

dan - za

1. | 2. | *al*  $\text{Coda}$

22 F A7 F *mf* F Last time to Coda F C7

— dí - a. — (el) dí - a. — Es-ta es la gai-ta es-ta es la gai-ta es-ta es la gai-ta de A-ni-ce-to Ron-  
 — ga - nas. (con)ga - nas. *mf* Es - ta es la gai-ta es-ta es la A - ni-ce-to Ron-

— (a) Es - ta es la gai-ta es-ta es la A - ni-ce-to Ron-

la. la. *mf* Es - ta es la gai-ta de A-ni-ce-to Ron-

la 1. En la la. *mf* Es - ta es la gai-ta de A-ni-ce-to Ron-  
 2. Es - ta

25 F F D7 Gm Gm

dón, hom-bre cul - to de cien-cia mu-si - do a - quel que la se - pa can -  
 dón, es la gai - ta tien - do a - quel mu - si - a - quel  
 dón, es la cul - to si - cal a - quel  
 cul - to mu - si - cal a - quel

1. F6 C7 | 2. F6

ven-ga pres-to pa-ra es-te pa-ran - dón. Es-ta es la dón.  
 se - pa can-tar ven-ga pres-to pa-ra es-te pa-ran - dón. Es - ta es dón.  
 se - pa can-tar ven-ga pres-to pa-ra es-te pa-ran - dón. Es - ta es dón.  
 se - pa can-tar ven-ga pres-to pa-ra es-te pa-ran - dón. Es - ta es la dón.

FAMP 321



## Text

### 1 He venido a despedirme

Letra y Música: Anónimo  
Versión Coral: Jesús Ochoa  
Bolivia

No te extrañes mi amada  
si a deshoras vengo a cantar,  
y te pido me perdones  
si tu sueño vengo a turbar.

He venido a despedirme  
porque pronto me voy a ir,  
y te juro que como hombre  
mi promesa voy a cumplir.

No creas que por mi ausencia  
yo te llégue a olvidar,  
adiós pues amada mía  
duérmete y vuelve a soñar.

### 2 Cana-fita

Letra y Música: Anónimo  
Versión Coral: Eduardo Lakschevitz  
Brasil

Eu aprantei cana  
na resta do só.  
Pra nascê mió:  
nasceu a cana-fita.

A usina apita,  
cana nas istêra.  
Assuca de primêra  
tem a cô bonita.

### 3 Natal

Letra y Música: Ernani Aguiar  
Brasil

¡O anjo anunciou!  
E'ó outro logo gritou:  
Jesus nasceu!  
Um pastor adormecido  
acordou meio aturdido:  
¿O que? ¿Quem nasceu?  
Então todos os pastores,  
Perguntaram com temores:  
¿Quem nasceu, aonde?

Em coro os anjos cantavam:  
'Em Belém, em Belém'  
e apontavam a direção  
da cidade onde havia nascido  
O Rei do amor da bondade.

Uma estrela brilhante,  
apareceu nesse instante  
iluminando o caminho  
que levava a Jesus menininho.  
Foram então os pastores  
pela estrada a cantar:  
¡Gloria a Deus nas alturas!  
¡Vamos Jesus encontrar!  
Belém, Belém.  
E dois mil anos depois tanto tempo  
continuamos cantando nos Natais  
sempre exultando,  
e ao Filho de Deus louvando.

### I have come to say goodbye

Text and music: Anonymous  
Choral version: Jesús Ochoa  
Bolivia

Do not wonder my love  
if I come to sing after hours,  
and I ask you to forgive me  
if I disturb your sleep.

I've come to say goodbye  
because I'm going soon,  
and I swear that as a man  
I will fulfill my promise.

Do not think that in my absence  
I will forget you,  
goodbye then, my love,  
go back to sleep and dream again.

### Sugar Cane

Text and music: Anonymous  
Choral version: Eduardo Lakschevitz  
Brazil

I planted sugar cane  
where there is sunshine  
so it would grow better;  
and a striped sugar cane was born.

The factory whistles,  
sugar cane is in the mill,  
first rate sugar  
has a beautiful color.

### Christmas

Text and music: Ernani Aguiar  
Brazil

The angel announced!  
and the others shouted:  
Jesus was born!  
A sleeping shepherd  
woke up dazed and said:  
What? Who was born?  
then all shepherds,  
asked with fear:  
Who was born, and where?

Choirs of Angels were singing:  
'In Bethlehem, in Bethlehem'  
and pointed to the city where  
the King of love and goodness  
was born.

A bright star  
appeared at that moment  
lighting the way  
that led to where little Jesus was.  
The shepherds went singing  
on their way to Bethlehem:  
Glory to God in the highest!  
we will soon meet Jesus!  
'In Bethlehem, in Bethlehem'  
And two thousand years later, after so long,  
we continue singing Christmas Carols,  
always rejoicing,  
and praising the Son of God.

**4** **Cántica No 8**  
Letra y Música: Luis Antonio Escobar  
Colombia

El de sombrero 'e jipa  
no sirve pa' enamorar.  
Y el de sombrero 'e jieltro,  
y ese sí a medio mirar.

He de dar y he de dar,  
hasta que de a la porjía,  
hasta que la haga chispiar  
su jeta contra la mía.

**5** **El torito**  
Letra y Música: Anónimo  
Versión Coral: Pedro Antonio Silva  
Costa Rica

Que te coja el toro Simona!  
Que te coja el toro Marcela.

Échame ese toro pinto  
hijo de la vaca mora,  
para sacarte una suerte  
delante de mi señora.

Si ese toro me matare  
no me entierren en sagrado,  
entiérrenme en campo afuera  
donde me pise el ganado.

Que te coja el toro Simona  
que te coja el toro Marcela.

No murió de calentura  
ni de dolor de costado,  
murió de una cornada  
que le dio el toro pintado.

Allá en aquel rincón  
pintado de colorado,  
allí están las cinco letras  
donde murió el desdichado.

**6** **Paisaje**  
Letra: Felipe González  
Música: Guido López Gavilán  
Cuba

La luna es una piñata  
repartida para todos,  
que entre montañas y lodos  
vierte sus luces de plata.  
El río es una corbata  
entre la palma y el llano,  
y el campesino cubano  
lleva en su hermoso atavío,  
toda el alma del bohío  
hecho de palmas y guano.

**Cántica No 8**  
Text and music: Luis Antonio Escobar  
Colombia

The one with the straw hat  
is not good for love,  
but the one with the felt hat  
looks flattering at women.

I have to try and try,  
I have to insist obstinately,  
until her mouth sparks  
against mine.

**The bull**  
Text and music: Anonymous  
Choral version: Pedro Antonio Silva  
Costa Rica

The bull will gore Simona,  
the bull will gore Marcela.

Let me fight that spotty bull  
who is the son of the black cow,  
so that I can show you my strength  
before my patroness.

If the bull kills me  
do not bury me in a sacred place,  
instead bury me in the open field  
where cattle graze.

The bull will gore Simona,  
the bull will gore Marcela.

He did not die of fever  
nor of rib pain,  
he died of goriness  
from the spotted bull.

In that corner  
painted in red color  
you can see the five letters  
where the unhappy man died.

**Landscape**  
Text: Felipe González  
Music: Guido López Gavilán  
Cuba

The moon is like a hollow figure  
filled with candies distributed to all.  
Between mountains and marshes  
she pours her silver light.  
The river is like a tie  
between the palm tree and the plain,  
and the cuban peasant  
carries in his beautiful attire,  
the soul of his hut  
made of diverse palm trees.

7

**La rosa y el clavel**

Letra y Música: Anónimo  
 Versión Coral: Jesús Albert Hernández  
 Chile

La rosa con el clavel, mi vida,  
 hicieron un juramento  
 y pusieron de testigo, mi vida,  
 a un jazmín y a un pensamiento.

Ay, no me tires con rosas  
 que tiene espinas,  
 tírame con violetas  
 que son más finas.

Ay, rosa con dalia,  
 dónde irá mi negrito,  
 ay que yo no vaya.

**The rose and the carnation**

Text and music: Anonymous  
 Choral version: Jesús Albert Hernández  
 Chile

The rose and the carnation, my love,  
 made an oath,  
 and chose as witnesses, my love,  
 a jasmin and a pansy flower.

Ah, do not throw me roses  
 because they have thorns,  
 throw me violets  
 because they are more refined.

Ah, rose and dahlia,  
 where will my beloved bold go  
 without me.

8

**El barreño<sup>1</sup>**

Letra y Música: Anónimo  
 Versión Coral: Alberto Grau  
 Guatemala, Salvador y Honduras

De los caballitos  
 que me trajo usted  
 ninguno me gusta,  
 solo el que maté.

Hágase pa' cá,  
 hágase pa' llá,  
 que mi caballito  
 lo atropellará.

Allá viene un lecherito  
 con su cántaro de plata,  
 y la niña le responde  
 esa leche a mí me mata.

Ay barreño sí,  
 ay barreño no,  
 dueño de mi corazón.

Cuando yo me muera  
 quien me enterrará sólo  
 las hermanas de la Caridad.

Cuando este barreño vino  
 no lo sabían bailar,  
 hora que todos lo saben,  
 no lo dejan descansar.

<sup>1</sup> El nombre de 'barreño' asignado a esta danza no se relaciona con una 'cubeta'. Apparently, this name can also mean 'barrio' (neighborhood).

**The basin<sup>1</sup>**

Text and music: Anonymous  
 Choral version: Alberto Grau  
 Guatemala, Salvador and Honduras

Of all the little horses  
 you brought me  
 I only liked  
 the one I killed.

Come here,  
 go there, be careful!  
 or my little horse  
 will run you over.

There comes a little donkey  
 with a silver basin,  
 and the girl says  
 'I love that milk'.

Ah, my basin, yes,  
 my basin, no,  
 my dear basin.

When I die,  
 I want the sisters of charity  
 to bury me.

When this basin arrived,  
 nobody knew how to dance,  
 now that they all have learned,  
 they cannot leave it in peace.

<sup>1</sup> The name 'barreño' is given to this dance without any relationship to a basin. Apparently, this name can also mean 'barrio' (neighborhood).

9

**La golondrina**

Letra y Música: Narciso Serradell  
 Versión Coral: Alberto Grau  
 México

A dónde irá la golondrina  
 buscando abrigo,  
 a dónde irá veloz y fatigada,  
 la golondrina que de ahí se va.

Oh, si en el cielo se hallará extraviada  
 buscando abrigo y no lo encontrará.

Junto a mi pecho le pondré su nido  
 en donde pueda la estación pasar,  
 también yo estoy en la región perdida,  
 ¡oh! cielo santo sin poder volar.

**The swallow**

Text and music: Narciso Serradell  
 Choral version: Alberto Grau  
 Mexico

Where will the swallow go for refuge,  
 where will she go so fast and tired,  
 that swallow that is leaving there?

If she gets lost in the sky,  
 she will surely find shelter.

Besides my heart I will put her nest,  
 where she can stay during the seasons,  
 because I am also in a lost space,  
 oh! good gracious, not being able to fly.

**10 Mariposa candorosa**

Letra: Rosa Carreto  
Música: José Antonio Rincón  
México

Mariposa candorosa  
ven alegre canta mi canción.

Traviesa una mariposa  
de bellissimo color  
de una rosa sobre el cáliz  
el raudo vuelo paró.

Después huyó la inconstante  
quedó en su tallo la flor,  
tu amor fue la mariposa  
la rosa mi corazón.

Rápido el viento de un lago  
la superficie besó.

En un hermoso lago el sol brillaba  
y el cenizante feliz de amor cantaba  
halagándole un momento  
con sus caricias de amor.

Huyó el céfiro ligero  
el lago no se movió  
tu amor era el vientecillo  
y el lago mi corazón.

**11 Aniceto Rondón**

Letra y Música: Anónimo  
Versión Coral: Jesús Ochoa  
Venezuela

Esta es la gaita de Aniceto Rondón  
hombre culto de ciencia musical,  
todo aquel que la sepa cantar  
venga presto para este parrandón.

En la ventana ponían  
bandera al que le tocaba  
hacer la fiesta y paga  
¡ay, caramba!  
hasta amanecer el día

Esta gaita veterana  
con ritmo de contradanza  
el Saladillo a la usanza  
¡ay, caramba!  
al Zulia canta con ganas.

<sup>2</sup> Gaita es un género musical del Estado Zulia en Venezuela.

<sup>3</sup> Contradanza proviene de 'danza regional', está escrita en un patrón de 2/4 y es el ancestro de la Gaita.

<sup>4</sup> El Saladillo es un barrio tradicional de Maracaibo que es la capital del Estado Zulia en Venezuela.

**Innocent Butterfly**

Text: Rosa Carreto  
Music: José Antonio Rincón  
Mexico

Innocent butterfly,  
come happily and sing my song.

A naughty butterfly,  
of beautiful colors  
perched on the calyx of a rose  
in a rapid flight.

Afterwards, the fickle fled,  
but the flower remained.  
Your love was the butterfly,  
and the rose my heart.

Swift and fast  
the wind kissed the lake.

In a beautiful lake the sun was shining  
and the happy bird was singing of love,  
faltering himself for a moment  
with love caresses.

The light zephyr fled!  
and the lake did not move.  
your love was the wind  
and the lake my heart.

**Aniceto Rondón**

Text and music: Anonymous  
Choral version: Jesús Ochoa  
Venezuela

This is the gaita<sup>2</sup> of Aniceto Rondón,  
educated man in musical science,  
everyone who can sing it,  
shall come quickly and join this group.

In the window there was a poster,  
looking like a flag that said:  
'the one who makes the party, pays for it'  
ah! Good gracious!  
and the party lasted until dawn.

This veteran gaita  
with a rhythm of contradanza<sup>3</sup>  
in the fashion of el Saladillo<sup>4</sup>  
ah! Good gracious!  
to the Zulia sings with love.

<sup>2</sup> Gaita is a musical genre of the Zulia state in Venezuela.

<sup>3</sup> Contradanza, from 'country dance', is a dance in 2/4 rhythm, from where the gaita originated.

<sup>4</sup> El Saladillo is a traditional neighborhood in Maracaibo, the capital of Zulia state in Venezuela.

**Caracolitos chicos**

Letra: Fragmentos de Federico García Lorca  
Música: Alberto Grau

Caracolitos chicos,  
mi niño, ¿dónde está?  
Quiere ser un caballo,  
mi niño, ¿dónde está?

Cantan niños en la noche serena.  
El río viejecito va muy despacito,  
sentándose en la sillas verdes de los remansos.

Mi niño, ¿dónde está?  
Quiere ser un caballito.

Arre, arre caballito.  
Mi niño, qué loquillo,  
cantando quiere salirse de mi corazón cerrado.

Caracolitos chicos, caracoles blancos,  
mi niño, ¿dónde está?

Los niños juegan y cantan bajo los álamos.  
Ay cantan los niños en noche serena.

**Little snails**

Text: Fragments from Federico García Lorca  
Music: Alberto Grau

Little snails,  
where is my child?  
He wants to be like a horse.  
Where is my child?

The children are singing in the calm night  
and the old river flows slowly  
sitting itself in the green chairs of the meadows.

Where is my child?  
He wants to be like a horse.

Hey, hey my little horse,  
my little crazy child screams,  
and wants to get out of my closed heart.

Little snails, white snails,  
where is my child?

The children sing and play under the trees,  
and the children sing in the calm night.

**Pronunciation guide**

for the Spanish language:

a	<i>ah</i> as in father
e	<i>ay</i> as in say
i	<i>ee</i> as in fee
o	<i>oh</i> as in foe
u	<i>oo</i> as in fool
y	<i>y</i> as in year
ll	<i>j</i> as in joy
que, qui	do not pronounce the 'u' sound as kay or kee

for the Portuguese language

(The vowels are pronounced as in Spanish, see above):

nh	<i>ny</i> (as if saying the word "Spain" in Spanish: "Espanya")
x	<i>sh</i> as in shadow
ao	<i>ao</i> as in wao!
lh	<i>lj</i> as in ljoy
o	<i>ou</i> as in owl
ch	<i>sh</i> as shadow

## Program notes

### 1. He venido a despedirme

This composition is a Chilean 'Cueca,' which is a dance found in many South American countries that is derived from the Spanish 'Jota'<sup>1</sup> and contains several elements from the 'Fandango.'<sup>2</sup> There are many different styles of 'Cuecas', depending on the nature of the texts or the region from which they come. However the rhythm is mostly written in 6/8, alternating sometimes with 3/4, and in minor keys, and it is danced in single and independent couples. Because of its melancholic character, this 'Cueca' is thought to have derived from the Peruvian 'Yaraví'<sup>3</sup> and it comes from the province of Sucre and was composed in the times of the Chaco war (that occurred between Bolivia and Paraguay in 1932–1935). Most of the authors who composed texts and popular tunes in this period are anonymous. The instruments that accompany the 'Cueca' are generally guitar, bombo<sup>4</sup> and charango.<sup>5</sup>

### 2. Cana-fita

This is a Brazilian popular melody compiled by Mário de Andrade (1893–1945) in his collection *Ensaio sobre a música brasileira* (1928). He was an ethnomusicologist who traveled around his country collecting data in order to preserve the ancestral memory of indigenous tribes, slaves from Africa and Portuguese settlers. He was one of the most important musicologists of the 20th century in Brazil, as well as a poet and writer who contributed alongside to Heitor Villalobos (1887–1959) to establishing Brazilian Nationalism. This song *Cana-fita* is a work song from Pernambuco<sup>6</sup> which has the 'coco' rhythm<sup>7</sup> and describes life at a sugar plantation. The choral version of Eduardo Lakschevitz, uses the main melody in a set of variations, alternating from the high to the low register of the choir. The percussion accompaniment of the instrumental group enhances the body percussion which the choir is asked to perform.

### 3. Natal

This original composition by Ernani Aguiar is a happy and vivid Christmas song. To enhance the words of exclamation of the Angels upon the birth of Christ, Aguiar uses a sharply articulated rhythmic figure in contrast to a more subdued melodic line that describes the sleeping shepherds. As the piece progresses, the vitality of the rhythm is driven by rapidly articulated syllables and an ongoing syncopated rhythm. The guitar accompaniment gives this composition the character of bossa nova.<sup>8</sup>

### 4. Cántica No 8

This composition belongs to Escobar's collection of choral works entitled *Cánticas Colombianas*, which are inspired by the traditions and texts of the Colombian peasants, with whom he came in contact during his childhood in Villapinzón, the village where he was born. These songs are based on the poetic form of the 'Copla,' which combines verses of eight and seven syllables, and uses slang words and expressions from popular sayings. These, in turn, are derived from the old Castilian language. The poems have grace and humor and are courtly love texts.

### 5. El torito

This is a sensual pantomime and dance from the region of Guanacaste in Costa Rica in which a couple imitates a Spanish bullfight. In this scene, while dancing and playing the role of the bull, the man tries to kiss the woman, who herself is playing the role of the bullfighter. Usually there are six couples dressed in bright colors and decorated hats. This dance, also known as 'Parrandera,' dates to the colonial days and similar dances are also found in Nicaragua and Salvador. The 2/4 meter with a continuous triplet rhythm in the bass line is characteristic of this dance. The accompanying instrumental ensemble includes a rich percussion section, as well as guitars and trumpets.

### 6. Paisaje

This original work for equal voices from the composer Guido Lopez Gavilan is a virtuoso composition, full of humor and lyricism. The composer uses onomatopoeic sounds that imitate the guitar and the mandolin, instruments that always accompany serenades and love songs. The poem describes a bucolic landscape and the verses alternate with vocal-instrumental interludes which help to build to an extraordinary sonic climax. The colorful harmonies are reminiscent of the impressionist language.

### 7. La rosa y el clavel

This song is a popular 'Cueca brava,' also known as 'Cueca Chilenera.' The 'Cueca' was designated a national dance in Chile since 1979 and it has been danced throughout this country since the early 19th century, both in the country-

<sup>1</sup> Jota: This is a Spanish dance, usually written in 3/4 meter, but many use in 6/8 meter which adapts better to the choreographic and strophic cycle of the dance. For its interpretation, different instruments are used depending on the region.

<sup>2</sup> Fandango: Also a Spanish dance, that relates to the Jota. It also uses 3/4 and 6/8 meters, but the character is more lively. There is a typical descending harmonic sequence (A minor, G major, F major, E major), an ostinato motif, known from the early days of the dance.

<sup>3</sup> Yaraví: comes from the Quechua word 'Haraví' and is a song of memories and longings. It combines Inca melodic traditions with troubadour poetry. Many songs were composed by mestizos of provincial towns in the Peruvian highlands since the 18th century.

<sup>4</sup> Bombo: a bass drum, made of wood and two patches of leather in each side. It derives from the turkish drum that later became popular in England as a 'long drum'. The patches are tuned by the tension of the strings attached to them.

<sup>5</sup> Charango is a stringed instrument, derived from the Spanish vihuela, that is used in the region of the Andes. It originated in Potosí, Bolivia in the 16th century. Generally, it has five doubled strings, but there is a wide variety of charangos in the Andean region.

<sup>6</sup> Pernambuco is one of the 26 states that form, together with the Federal District, the Federal Republic of Brazil. It is located in the center of the northeast region.

<sup>7</sup> Coco rhythm: is a rhythm that originated in the North East part of Brazil. It is a binary rhythm with clearly displaced accents that produce interesting syncopations. 'Coco' means 'head', and the songs using this rhythm are simple ones, originated from the african influence of 'working songs'. 'Coco' also means 'coconut' and the percussion instruments try to imitate the sound of clashing shells of this fruit. It is usually danced in pairs and the percussion group is formed by a rattle drum, djembé or congas, tambourine and triangle.

<sup>8</sup> Bossa nova is a genre derived from the samba, which was influenced by jazz harmonies. The word comes from the 'new way' of reformulating the modern urban samba. The bossa nova is a genre of popular Brazilian music derived from the samba.

side and in the cities. The styles of the 'Cuecas' are different according to the nature of the texts and to traditions of each region. The origin of the 'Cueca' is unclear, but certainly it developed in the Viceroyalty of Peru, first as a dance called the 'zamacueca',<sup>9</sup> which in turn originated from the 'jota' and the 'fandango.' It is danced in couples who dance apart from each other while waving red scarves and moving in circles. The musicologist Carlos Vega writes: "it is possible to consider the 'Cueca' as a parody of courtship between a cock and a hen: the scarves could symbolize feathers or ridges within a choreography that is characterized by loose interdependent partners." In describing the 'Cueca' another musicologist, Samuel Claro, explains that "the choreography recalls the ancient or medieval tournaments and derives from the pantomime of love ..." It is a festive and cheerful dance, accompanied by guitars, harp, accordion and percussion instruments, although it is written mostly in minor keys. The rhythm combines measures of 6/8 and 3/4.

### 8. El barreño

*El barreño* (The basin) is a folkloric dance which is found in various countries in Central America such as El Salvador, Honduras and Guatemala. It is said to have originated in the 18th century in Cuscatlán, one of the provinces of El Salvador. The accurate name of the dance is not clear, and 'barreño' refers to 'barrio' (neighborhood) where this dance became very popular. This dance, reminiscent of the medieval traditions, develops around elements of courtship and flirtation which are reflected in the choreography. The choral version published in this edition stresses the rhythmic figures and syncopations typical of this dance.

### 9. La golondrina

It was composed in 1862 as a song of exile or farewell by a young Mexican soldier who was captured by the French army and taken prisoner. It became an iconic popular anthem for all Mexican exiles. The author's intention was to contrast the image of the Eagle as a symbol of might with that of a simple and docile bird, such as the swallow. This song, in the style of a serenade, has been interpreted in many versions by great popular and opera singers.

### 10. Mariposa candorosa

This song is a graceful and refined Mexican Danzon full of humor. The 'Danzón' is a rhythm of Cuban origin, but since the early 20th century it developed deep roots in Mexico and is also considered part of the popular culture of that country. The 'Danzón' was created by the Cuban composer Miguel Failde (born ca. 1879), and it is derived from the European 'Contradanza' (see under *Aniceto Rondón*) which was influenced by African traditions and became known the Creole Cuban Dance or Habanera. It is a sensual, expressive and syncopated dance. Usually accompanied by flute, timbales, guiro, claves and piano. Other dances, such as the 'Cuban Son,' 'Chachachá' and 'Mambo' originated from the 'Danzón.'

### 11. Aniceto Rondón

The 'Contradanza' came from Europe to America with the immigration from Spain. In various cities of the Caribbean it mingled with African rhythmic patterns, transforming itself into a rhythmic and syncopated dance. Since the early 19th century it became very popular in the city of Maracaibo, located in western Venezuela, and many composers wrote and developed this genre of music. It evolved into the very popular genre of the 'Gaita Zuliana.'

### 12. Caracolitos chicos

This virtuoso composition for women's choir, belongs to a group of works that Grau wrote for ensembles searching for new aesthetic ideas. The text of García Lorca, which serves as a point of departure, is only a short selection of playful verses describing the natural and untamed character of a child that imitates a horse. This is why the composition combines different layers of polyrhythmic textures in the choral parts with body percussion – these are fully interconnected and must be interpreted as a whole. The intention of the composer is that the piece develops into a festive and happy experience on the stage.

<sup>9</sup> Zamacueca is the combination of two words: 'samba' which means dancing and 'cave' is a word that expresses the state of nervousness of a broody hen against the rooster.

## Biographies

### Jesús Ochoa (\*1963)

Venezuelan choral conductor, composer and arranger, Ochoa was a member of the Schola Cantorum de Venezuela. He conducts several choral ensembles and has a good knowledge of popular music. His compositional language follows a traditional path and he is widely recognized as an arranger. He studied choral conducting with Alberto Grau and Ana Maria Raga and obtained his degree at the University of the Arts in Caracas.

### Eduardo Lakschevitz (\*1970)

The Brazilian conductor and composer, is Professor of Music History at the University of Rio de Janeiro (UNIRIO), holds a Doctoral degree in Music Education at the same University, and a Masters Degree in Choral Conducting from the University of Missouri-Kansas City (UMKC). Active as a teacher, conductor and clinician, he has worked in several Brazilian states, as well as in the US. In the early 90's Dr. Lakschevitz founded the NGO Oficina Coral, where he coordinated ten editions of the Choral Conducting International Course. At present, he develops corporate education programs through choral singing and promotes music tours in Brazil for American ensembles. He founded and directed the group KOLINA for five years. This is a vocal ensemble that specializes in the sacred music of Brazil, with which he has toured different states in South and North America, and has recorded two CDs. His compositions, articles, and arrangements have been recorded and published in Brazil, Venezuela, the United States and Slovenia.

### Ernani Aguiar (\*1950)

Ernani Aguiar is a Brazilian composer, choral conductor, and musicologist. A scholarship winner at the Argentine Mozarteum, Aguiar studied under various composers and conductors in South America and later in Europe, including the conductor Sergiu Celibidache. As a musicologist, he has specialized in the revising, editing, and revival of works by composers of the 18th century from the Minas Gerais School. He has written a number of instrumental pieces, but his most famous works are his choral pieces, such as the fiery *Salmo 150* (1993), which features rhythmic backgrounds with very a rapid articulation. *Salmo 150* has proven to be a very popular piece among choral conductors worldwide. He is currently a professor of music at the Federal University of Rio de Janeiro, a fellow of the Villa-Lobos Institute, and a member of the Academia Brasileira de Música.

### Luis Antonio Escobar Segura (1925–1993)

The native of Colombia, Luis Antonio Escobar Segura, was a musician, composer, and musicologist. His early musical training was heavily influenced by the Arevalo family in Villapinzón and later he completed his academic training in Bogotá, United States and Germany. He was an active conductor, professor, composer and radio broadcaster, and has been linked to the national musical movement since 1954. He has also held important positions both at home in the government of Colombia and in the consular service

abroad. In 1958 he received a Guggenheim Fellowship. His catalog of compositions is extensive and extremely varied and it appears in Volume 8 of the American Composers series, published by the Organization of American States (OEA) in 1962. He composed for many types of ensembles such as orchestras, soloists with orchestra, children's and female choirs, mixed choirs, stage works, and chamber ensembles. Some of his most important works are: the *Colombian Serenade*, *Divertimento No. 1*, *Concertino for Flute and Orchestra*, the *First Symphony* (1955), *Avirama* (ballet, 1956) and two operas *The Princess and the Pea* and *Gangsters*, based on a text by the poet Jorge Gaitán Durán. His best known choral works are his peasant cantatas, madrigals and songs for mixed choirs, and his *Cánticas Colombianas*.

### Pedro Antonio Silva (\*1961)

This Venezuelan composer and choral conductor studied in Caracas under professors Francisco Rodrigo, Tiero Pezzuti and Alberto Grau, among others. He graduated in choral conducting from the Conservatory of Music Simón Bolívar and was a member of the Schola Cantorum de Venezuela. He conducts the Orfeón Universitario Simón Bolívar and several other choirs, and on various occasions he has also conducted some of the youth orchestras from *El Sistema*. At present he teaches at the *José Angel Lamas* and *Juan Manuel Olivares* music schools. His musical style is based on traditional harmonies that accompany inspired melodies, which in many occasions derive from popular sources.

### Guido López Gavilán (\*1944)

The Cuban composer and conductor Guido López-Gavilán graduated in 1966 from the choral conducting program at the Amadeo Roldan Conservatory in Havana and in 1973 from the Orchestral Conducting program at the Tchaikovsky Conservatory in Moscow. He has received awards in the most important composition competitions held in Cuba and as a conductor has achieved extraordinary success and received recognition from international critics for outstanding performances in Latin America and Europe. He has also been invited as a guest speaker to many important festivals and musical events at various prestigious universities. In 2005 he was awarded the UNESCO Medal in Chile. His piece *Conga*, especially written for the Sixth World Symposium of Choral Music, Minneapolis, USA, was premiered at the Symposium's opening concert. He has also made an outstanding contribution to the development of the Cuban Youth Orchestra Movement, is the President of the Havana Festival and Chairman of the Orchestral Conducting Department at the Instituto Superior de Arte. His style of composition incorporates rhythms from Cuban popular music, polytonality, unconventional sound resources and fine lyricism. His music ranges from humorous and joyful compositions to solemn and dramatic works.

### Jesús Albert Hernández (\*1956)

This Venezuelan composer and instrumentalist was born in Caracas. He began his musical life at a very early age, learning to play many instruments with family and friends, including the guitar, the mandolin, the bass guitar, the charango, the flute, the saxophone, among many others. His

musical training started formally in 1999 when he became a pupil of Modesta Bor and later obtained a Masters Degree in composition at the University Simón Bolívar. His musical style derives elements from jazz, popular and folk music.

#### **Alberto Grau** (\*1937)

This Catalan-Venezuelan distinguished composer and conductor won a place of honor among the greatest Venezuelan contemporary musicians. Known for his career as a choral conductor, he has become one of the leading figures in choral composition in Latin America, and many of his works have been published. His books on choral conducting and composition, *The making of a conductor* and *The making of the composer*, are references for young conductors and musicians. In 1967 he founded the Schola Cantorum de Caracas and won first prize in the Guido D'Arezzo International Competition in 1974 in Italy. Since then, he has been invited to many important conferences and festivals with his ensembles and as a guest conductor. More than thirty recordings provide evidence of his fine musicianship and extensive knowledge of international and Latin American choral repertoire. He is also the Founding Director of both the Orfeón Universitario Simón Bolívar and the Coral Ave Fenix, and he is a member of the Board of Directors of *El Sistema* (Foundation for Children and Youth Orchestras and Choirs of Venezuela). He is an adviser and resident composer in the Pequeños Cantores Program at the Schola Cantorum de Venezuela Foundation and at the CAF/Latinamerican Bank of Development Program of Social Action for Music.

#### **Narciso Serradell** (1843–1910)

was a doctor and composer, who was exiled in France during the Second French Intervention in Mexico. While in France he taught music and Spanish and composed his most emblematic song *La Golondrina* which became a hymn of Mexican exiles.

#### **José Antonio Rincón** (\*1937)

Colombia-Mexican pedagogue, composer and choral conductor. He studied at the National University of Colombia, at the Musical Institute in Chile and at Queens College, New York. He has founded several choirs in Colombia, Venezuela and Mexico, where he has lived since 1980. As a composer he has devoted himself to writing 'a cappella' choral works and choral arrangements based on Afro Caribbean musical traditions.

### **The Companion CD**

1 – 11 Music (Carus 2.502)

12 Music *Caracolitos chicos* (Carus 9.935)

13 – 24 Pronunciation guide (see also pp. 63–67)

#### **CANTORIA ALBERTO GRAU**

Founding Conductor and Artistic Director: María Guinand

Conductor: Victoria Nieto

Vocal coach and soloist: Verónica Sosa

#### *Sopranos*

Anaida Carquéz

Desirée Agüero

Iris Pagano

Astrid Villar

Mariana Díaz

#### *Mezzosopranos*

Verónica Sosa

Dailizeth Guzmán

Elizabeth Viera

Isabel Hernández

#### *Altos*

Wilma Cedeño

Victoria Nieto

Jennifer Calatrava

María Fernanda López

Instrumental arrangements: Jesús Albert Hernández

#### Instrumentalists:

Luimar Arismendi (mandolin, guitar, cuatro, percussion)

Jesús Albert Hernández (guitar, cuatro, flute, quena,

bass, percussion)

Recorded in Caracas at Novus Artis Studio, April 2014

and in Caracas, Sala José Félix Ribas, 1998, 2009

Sound engineer: Jesús Albert Hernández

Carus in cooperation with IFCM

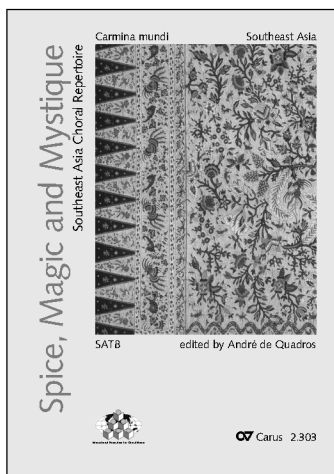

Spice, Magic and Mystique  
Choral Repertoire from **Southeast Asia**  
for mixed choir  
edited by André de Quadros  
Carus 2.303

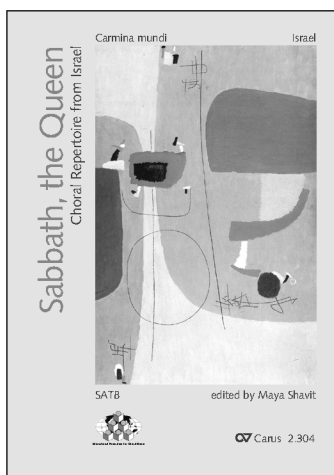

Sabbath, the Queen  
Choral Repertoire from **Israel**  
for mixed choir  
edited by Maya Shavit  
Carus 2.304

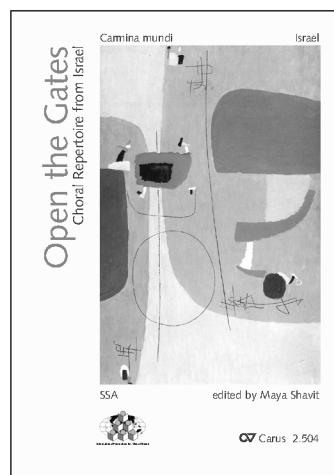

Open the Gates  
Choral Repertoire from **Israel**  
for equal voices  
edited by Maya Shavit  
Carus 2.504

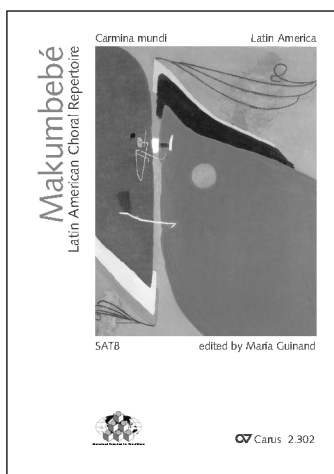

Makumbé  
Choral Repertoire from **Latin America**  
for mixed choir  
edited by María Guinand  
Carus 2.302

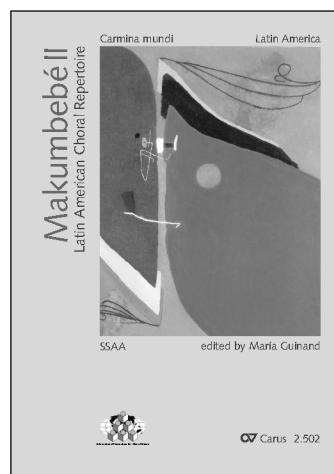

Makumbé II  
Choral Repertoire from **Latin America**  
for equal voices  
edited by María Guinand  
Carus 2.502

Diese Reihe wird in Verbindung mit IFCM fortgesetzt. This series will be continued in cooperation with IFCM.