

Jean Langlais  
Missa Misericordiae  
Domini 1958

---

Coro STB (SAB) ed Organo

Reprint der Erstausgabe (1959)  
des Gregorian Institute of America

Partitur / Full score

---

## A propos de la *Missa Misericordiae Domini*

*“J’ai composé ma *Missa Misericordiae Domini* à la requête du Père Schmidt (à qui l’oeuvre est dédiée), maître de chapelle et responsable de la musique liturgique à Boystown, Nebraska (Etats-Unis), petite ville créée par un prêtre irlandais, le Père Flanagan, pour accueillir et prendre en charge des enfants dévoyés ou maltraités. Cette Fondation remarquable organisait chaque année un Séminaire d’Été de Musique Sacrée auquel j’ai participé à cinq reprises. C’est pour celui de 1959 que j’ai composé, entre le 15 et le 18 Septembre 1958, cette *Missa Misericordiae Domini* pour 3 voix (Soprano, Ténor, Basse) et orgue, selon le désir du Père Schmidt dont la chorale de garçons était alors dépourvue de voix d’altos.*”

*Le Gregorian Institute of America édita cette oeuvre en 1959, puis en abandonna le copyright une fois la vente épuisée. Conçue pour un chœur d’une centaine de garçons, la *Missa Misericordiae Domini* peut néanmoins parfaitement être chantée par un chœur mixte de dimension plus modeste. Les registrations et les nuances de l’orgue devront tenir compte de la taille et de la puissance du chœur.”*

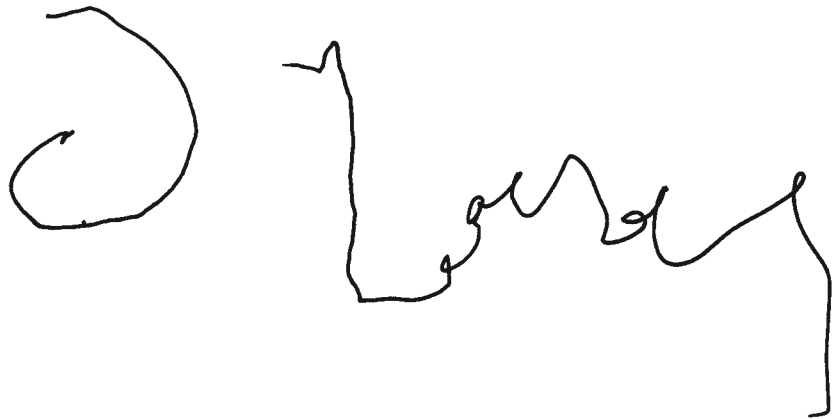

“Ich habe meine *Missa Misericordiae Domini* auf die Bitte von Pater Schmidt (dem das Werk gewidmet ist) komponiert; er ist Kapellmeister und für die liturgische Musik in Boystown, Nebraska (USA) verantwortlich. Dieses kleine Dorf wurde von einem irischen Priester, Pater Flanagan, gegründet, um problematische und mißhandelte Kinder aufzunehmen und zu versorgen. Diese bemerkenswerte Stiftung organisiert jährliche Sommerseminare für Sakralmusik, an denen ich fünfmal teilgenommen habe. Für dasjenige von 1959 schrieb ich zwischen dem 15. und dem 18. September 1958 diese *Missa Misericordiae Domini* (‘Messe von der Barmherzigkeit des Herrn’) für drei Stimmen (Sopran, Tenor, Baß) und Orgel, einem Wunsche Pater Schmidts entsprechend, dessen Knabenchor damals keine Altstimmen zur Verfügung hatte.

Das Gregorian Institute of America legte das Werk 1959 im Druck vor; nach Verkauf der Auflage gab sie das Copyright ab. Obwohl für einen hundertköpfigen Knabenchor konzipiert, kann die *Missa Misericordiae Domini* nichtsdestoweniger genau so gut von einem nicht allzu großen gemischten Chor gesungen werden. Die Registrierungen und dynamischen Abstufungen der Orgelbegleitung müssen auf dessen Größe und Klangvolumen abgestimmt sein.”

Zu dieser Messe gibt es, dem Vorschlag Langlais folgend, seit 1995 eine Chorpartitur für Chor SAB.

# Missa Misericordiae Domini

## Kyrie

Jean Langlais  
1907-1991

Andantino ♩ = 76

Soprano

Alto/  
Tenore

Basso

Ky-ri-e e-lei-son.

Organo

Andantino ♩ = 76

6

Ky-ri-e e-lei-son.

son.

Ky-ri-e e-lei-son.

Aufführungsdauer/Duration: ca. 14 min.

© 1989/1995 by Carus-Verlag, Stuttgart – CV 27.016

Vervielfältigungen jeglicher Art sind gesetzlich verboten. / Any unauthorized reproduction is prohibited by law.

Alle Rechte vorbehalten / All rights reserved / 2022 / Printed in Germany / www.carus-verlag.com

8

son.

*mf*

Chri-ste e - lé - i - son.

12

*mf*

e e - son.

*mf* *p*

Chri - ste e - léi - son.

15

Musical score for two vocal parts and piano accompaniment, measures 15-17. The vocal parts are in treble clef with a key signature of one flat. The piano accompaniment is in bass clef. The lyrics "Ky" are written below the vocal staves. The dynamic marking *p* is present above the vocal staves.

Piano accompaniment for measures 15-17, showing the right and left hand parts.

18

Musical score for two vocal parts and piano accompaniment, measures 18-20. The vocal parts are in treble clef with a key signature of one flat. The piano accompaniment is in bass clef. The lyrics "ri - e - e -" are written below the vocal staves. The dynamic marking *mf* is present above the vocal staves.

Piano accompaniment for measures 18-20, showing the right and left hand parts.

20

*p* - lé - i - son. *div. ff.* Ky - ri - e

*p* - lé - i - son. *ff.* Ky - ri - e

*ff.* *mf* Ky - ri - e e - lé - i -

*mf*

23

*mf* *p* - ri - e e - lé - i -

*mf* *p* - ri - e

son. Ky - ri - e e - - - lé - i -

*mf* *p*

26

*pp*  
son.

*mf*  
Ky - ri - e e - lé - i - son.

*pp*  
son.

*mf*  
Ky - ri - e e - lé - i -

28

- e - lé - i - son.

son.

Ky - ri - e e - lé - i -

30

Ky - ri - e e - lé - i -

*p* Ky - ri - e e - lé - i - son.

son.

32

*rall* Ky - ri - e - lé - i - son. Ky - ri - e e - lé - i - son.

*pp* - e e - lé - i - son. Ky - ri - e e - lé - i - son.

*pp* Ky - ri - e e - lé - i - son.

# Gloria

1

Allegro ♩ = 88

*mf*

S. Et in ter - ra pax ho - mí - ni -

T.

B.

Allegro ♩ = 88

*mf*

7

*p* vo - tá - tis. *mf* Lau - dá - mus.

12 *p* te. *p* Ad - o - rá - mus -

*mf* Be - ne - dí - ci - mus te.

16 *mf* - fi - cá - mus - te. *mf* Grá - ti - as

á - gi - mus ti - bi pro - pter ma - gnam gló - ri - am - tu - am.

25 4

De - us, Rex cae - le - stis, De - us Pa - ter

31 5

o - mní - po - tens

Dó - mi - ne Fi - li u - ni - gé - ni - te,

37 6

Chri - ste.

Dó - mi - ne De - us,

43

Musical notation for the first system, including vocal line and piano accompaniment. The vocal line is in a soprano clef, and the piano accompaniment is in a bass clef. The key signature has one sharp (F#) and the time signature is common time (C). The vocal line has a long note on the first staff, followed by a series of notes in the second staff. The piano accompaniment starts with a bass line in the first staff and a chordal accompaniment in the second staff.

A - gnus De - i, Fí - li - us Pa - - tris. \_\_\_\_\_

Musical notation for the second system, including vocal line and piano accompaniment. The vocal line continues with notes in the soprano clef. The piano accompaniment continues with bass and treble staves.

49

7

Musical notation for the third system, including vocal line and piano accompaniment. The vocal line has notes in the soprano clef. The piano accompaniment continues with bass and treble staves.

Qui tol - lis pec - cá - ta mun - di:

Musical notation for the fourth system, including vocal line and piano accompaniment. The vocal line has notes in the soprano clef. The piano accompaniment continues with bass and treble staves.

52 8

*mf* *p* *f*

mi - se - ré - re no - bis. Qui tol - lis

*mf* *p* *f*

mi - se - ré - re no - bis. Qui tol - lis

*mf* *p* *f*

mi - se - ré - re no - bis. Qui tol - lis

55

- cá - mun - di: sú - sci - pe —

pe - ta mun - di: sú - sci - pe

- cá - ta mun - di: sú - sci - pe

de - pre - ca - ti - ó - nem no - stram. *p*

de - pre - ca - ti - ó - nem no - stram. *p* *mf* Qui

de - pre - ca - ti - ó - nem no - stram. *p*

Piano accompaniment for measures 58-60, featuring a grand staff with treble and bass clefs. The music is in G major and 3/4 time, with a tempo of quarter note = 120. The accompaniment consists of chords and moving lines in both hands.

se - d d dex - te - ram Pa - tris, *f* mi - se -

se - d d dex - te - ram Pa - tris, *f* mi - se -

Piano accompaniment for measures 61-63, featuring a grand staff with treble and bass clefs. The music is in G major and 3/4 time, with a tempo of quarter note = 120. The accompaniment consists of chords and moving lines in both hands.

65

10

*f*

Quó - ni - am

*p*  
ré - re - no - - - bis.

Piano accompaniment for measures 65-68, featuring a treble and bass clef with various chords and melodic lines.

69

so - lu san - ctus.

Tu - so - lus Dó - mi - nus.

Piano accompaniment for measures 69-72, featuring a treble and bass clef with various chords and melodic lines.

73

Tu — so — lus Al — tís — si — mus,

Tu — so — lus Al — tís — si — mus,

77

*p* Je — su — ri — ste. *f* Cum San — cto

*p* Je — su — ste.

Chri — ste.

81

Spí - ri - tu in — gló - ri - a —  
 in gló - ri - a  
 in gló - ri - a

84

i - tris. A - - - -  
 De Pa - tris.  
 De - i Pa - tris.

88

musical score for measures 88-91. It includes a vocal line with lyrics: "men." and "A - - - men. A -". The piano accompaniment consists of two staves with chords and melodic lines.

piano accompaniment for measures 88-91, showing chord progressions and melodic fragments in both hands.

92

musical score for measures 92-95. It includes a vocal line with lyrics: "A - - - men.", "men.", and "men.". The piano accompaniment continues with chords and melodic lines.

piano accompaniment for measures 92-95, showing chord progressions and melodic fragments in both hands.

# Credo

1

Allegro ♩ = 92

S. Pa - trem o - mni - po - tén - tem,

T. Pa - trem o - mni - po - tén - tem,

B. Pa - trem o - mni - po - tén - tem,

Allegro ♩ = 92

4

fa-ctó-rem cae-li et ter-rae, vi-si-bí-li-um ó-mni-um

ó-rem cae-li et ter-rae, vi-si-bí-li-um ó-mni-um

fa-ctó-rem cae-li et ter-rae, vi-si-bí-li-um ó-mni-um

7

2

et in-vi-si-bí-li-um. Et in u-num Dó-mi-num Je-sum

et in-vi-si-bí-li-um. Et in u-num Dó-mi-num Je-sum

et in-vi-si-bí-li-um. Et in u-num Dó-mi-num Je-sum

10

Christum, Fí-li-um De-i u-ni-gé-ni-tum.

Christum, Fí-li-um De-i u-ni-gé-ni-tum.

Christum, Fí-li-um De-i u-ni-gé-ni-tum.

13 3

Et ex Pa-tre na - tum an - te ó-mni - a sae - cu - la.

Et ex Pa-tre na - tum an - te ó-mni - a sae - cu - la.

Et ex Pa-tre na - tum an - te ó-mni - a sae - cu - la.

17 4

De - um De - o, lu - men de lú - mi - ne,

De - o, lu - men de lú - mi - ne,

De - um de De - o, lu - men de lú - mi - ne,

De-um ve - rum de De - o ve - ro. Gé - ni - tum, non  
 De-um ve - rum de De - o ve - ro. Gé - ni - tum, non  
 De-um ve - rum de De - o ve - ro. Gé - ni - tum, non

am, sub - stan - ti - á - lem Pa - tri: per quem  
 fa - tum, sub - stan - ti - á - lem Pa - tri: per quem  
 tum, con - sub - stan - ti - á - lem Pa - tri: per quem

29

6

ó - mni - a fa - cta sunt. Qui pro - pter nos hó - mi - nes

ó - mni - a fa - cta sunt. Qui pro - pter nos hó - mi - nes

ó - mni - a fa - cta sunt. Qui pro - pter nos hó - mi - nes

33

et pro - pter no - stram sa - lú - tem de - scén - dit de cae - lis.

et pro - pter no - stram sa - lú - tem de - scén - dit de cae - lis.

et pro - pter no - stram sa - lú - tem de - scén - dit de cae - lis.

36

7

*espressivo*  
*mf*

*mf*

Et in car - ná - tus - est de

38

San - - - cto,

40

ex Ma - ri - a Vir - gi - ne: Et ho - mo -

43

ctus e

46

8

Musical notation for the first system, including vocal staves and piano accompaniment.

*mf*

Cru-ci - fí - xus é - ti - am pro no - bis: sub Pón - ti - o Pi -

Musical notation for the second system, including vocal staves and piano accompaniment.

*mf*

Carus

49

9

Musical notation for the third system, including vocal staves and piano accompaniment.

Et re-sur-ré - xit

pas-sus et se-púl-tus est.

Et re-sur-ré - xit

Musical notation for the fourth system, including vocal staves and piano accompaniment.

tér-ti - a di - e, se-cún-dum Scri-ptú - ras.

tér-ti - a di - e, se-cún-dum Scri-ptú - ras.

Et a-scén dit in coe - lum: se-det ad déx-te-ram

Et a-scén dit in coe - lum: se-det ad déx-te-ram

Et a-scén dit in coe - lum: se-det ad déx-te-ram

57

11

Pa - tris. Et í - te - rum ven - tú - rus est cum gló - ri - a,

Pa - tris. Et í - te - rum ven - tú - rus est cum gló - ri - a,

Pa - tris. Et í - te - rum ven - tú - rus est cum gló - ri - a,

Piano accompaniment for measures 57-59, featuring chords and a bass line.

60

ca - ri - vi - vos et mór - tu - os: cu - jus re - gni

ju - ar - vi - vos et mór - tu - os: cu - jus re - gni

ca - re vi - vos et mór - tu - os: cu - jus re - gni

Piano accompaniment for measures 60-62, featuring chords and a bass line.

64

non e - rit fi - nis. Et in Spí - ri - tum

non e - rit fi - nis. Et in Spí - ri - tum

non e - rit fi - nis. Et in Spí - ri - tum

The musical score for measures 64-66 consists of three vocal staves (Soprano, Alto, and Bass) and piano accompaniment. The vocal parts are in a homophonic setting, with the lyrics "non e - rit fi - nis. Et in Spí - ri - tum" repeated on each staff. The piano accompaniment features a steady bass line and chords in the right hand. A large watermark "Canis" is overlaid on the score.

67

san-ctum - mi-num et vi - vi - fi - cán - tem:

san-ctum - mi-num et vi - vi - fi - cán - tem:

san-ctum Dó - mi-num et vi - vi - fi - cán - tem:

The musical score for measures 67-70 continues with three vocal staves and piano accompaniment. The lyrics are "san-ctum - mi-num et vi - vi - fi - cán - tem:" repeated on each staff, with the final measure of the third staff reading "san-ctum Dó - mi-num et vi - vi - fi - cán - tem:". The piano accompaniment provides harmonic support with chords and a moving bass line. A large watermark "Canis" is overlaid on the score.

qui ex Pa-tre Fi-li-ó-que pro-cé-dit.

qui ex Pa-tre Fi-li-ó-que pro-cé-dit.

qui ex Pa-tre Fi-li-ó-que pro-cé-dit.

qui ex Pa-tre Fi-li-ó-que pro-cé-dit.

Qui cum Pa-tre et Fi-li-o si-mul

75

ad - o - rá - tur et con - glo - ri - fi - cá - tur: qui lo-

77

cú - tus est per Pro - phé - tas.

80

Et u - nam,  
Et u - nam,  
Et u - nam,

82

san-ctam, ca - th - cam et a - po - stó - li - cam Ec -  
san-ctam, ca - th - cam et a - po - stó - li - cam Ec -  
san-ctam, ca - th - cam et a - po - stó - li - cam Ec -

84

15

clé - si - am. Con - fi - te - or

clé - si - am. Con - fi - te - or

clé - si - am. Con - fi - te - or

Piano accompaniment for measures 84-85, featuring chords in the right hand and a melodic line in the left hand.

86

u - num ba - ptís - ma in re - mis - si - ó - nem

u - num ba - ptís - ma in re - mis - si - ó - nem

u - num ba - ptís - ma in re - mis - si - ó - nem

Piano accompaniment for measures 86-87, featuring chords in the right hand and a melodic line in the left hand.

88

pec - ca - tó - rum. Et ex - spé - cto  
 pec - ca - tó - rum. Et ex - spé - cto  
 pec - ca - tó - rum. Et ex - spé - cto

Piano accompaniment for measures 88-89, featuring chords and melodic lines in the right and left hands.

90

sur - re - cti - ó - nem mor - tu - ó - rum.  
 re - re - cti - ó - nem mor - tu - ó - rum.  
 re - sur - re - cti - ó - nem mor - tu - ó - rum.

Piano accompaniment for measures 90-91, featuring chords and melodic lines in the right and left hands.

Carus

Et vi - tam ven - tú - ri sáe - cu - li.

Et vi - tam ven - tú - ri sáe - cu - li.

Et vi - tam ven - tú - ri sáe - cu - li.

Piano accompaniment for measures 92-95, featuring chords and melodic lines in the right and left hands.

men. A - - men.

men. A - - men.

A - men. A - - men.

Piano accompaniment for measures 96-99, featuring chords and melodic lines in the right and left hands.

# Sanctus

1

Andantino ♩ - 80

S. \_\_\_\_\_

T. \_\_\_\_\_

B. \_\_\_\_\_

Andantino ♩ - 80

*mf*

3

San - - - - ctus,

*p*

5 2

7

San - - - - ctus,

3

San - - - - ctus

4

- mi - nus De - us Sá - ba-oth.

14 5

*f* Ple - ni sunt cae - li et \_\_\_\_\_

*f* Ple - ni sunt cae - li et \_\_\_\_\_

*f* Ple - ni sunt cae - li et \_\_\_\_\_

17 6

ra gló - ri - a \_\_\_\_\_

ra gló - ri - a \_\_\_\_\_

ter - ra gló - ri - a \_\_\_\_\_

20

7

tu - - a. Ho - sán - na

tu - - a. Ho - sán - na

tu - - a. Ho - sán - na,

22

in cé - sis. Ho - sán - na in ex -

Ho - sán - na in ex -

Ho - sán - na in ex -

25 *rall.* To  
cél - - sis.  
cél - - sis.  
cél - - sis.

To

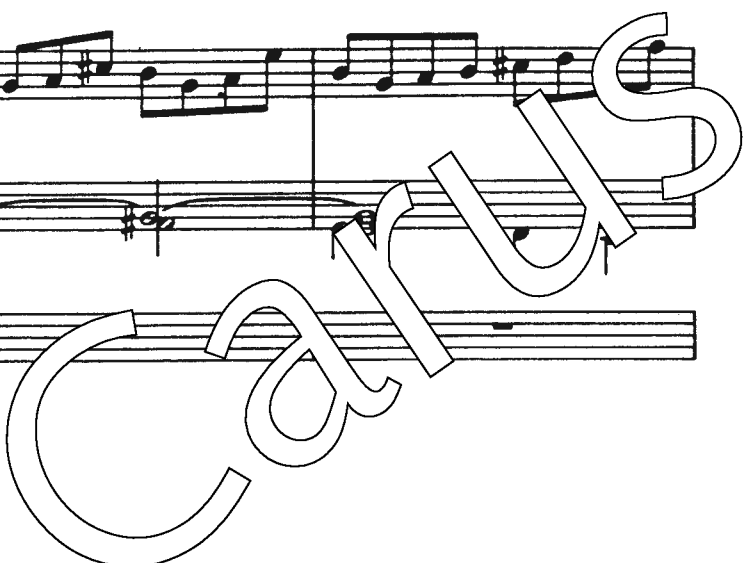
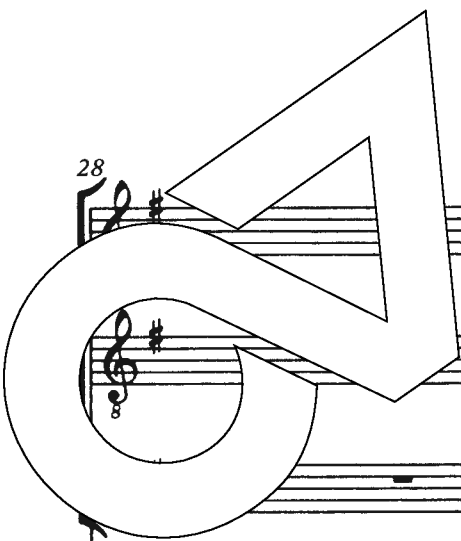

28

*rall.*

# Benedictus

S.  $\text{♩} = 76$

*p*

*p*

This system contains the first two measures of the piece. It features a Soprano line and a Piano accompaniment. The Soprano line is mostly rests. The Piano accompaniment begins with a melody in the right hand and a supporting line in the left hand, both marked with a piano (*p*) dynamic.

3

This system contains measures 3 and 4. The Soprano line has a melodic phrase starting in measure 3. The Piano accompaniment continues with a similar melodic pattern in the right hand and a bass line in the left hand.

Soprano *p*

ne - di - ctus, — *pp*

*p* *p*

This system contains measures 5 and 6. The Soprano line has the lyrics "ne - di - ctus, —" and is marked with a piano (*p*) dynamic. The Piano accompaniment features chords in the right hand and a bass line in the left hand, with dynamics of piano (*p*) and piano-piano (*pp*).

8 *mf*  
qui \_\_\_\_\_

10 *p*  
ve - nit in \_\_\_\_\_

*pp*  
nó - mi - ne \_\_\_\_\_ Dó - mi - ni. \_\_\_\_\_

16

$\text{♩} = 80$

Ho-sán - na

Ho-sán - na

Ho-sán - na

19

in ex - céls. Ho-sán - na in ex -

in ex - céls. Ho-sán - na in ex -

Ho-sán - na in ex -

22 *rall.* To  
cél - - - sis.  
cél - - - sis.  
cél - - - sis.

*rall.* To

25

*rall.*

# Agnus Dei

1

Andantino ♩ = 63

S  
T  
B

Andantino ♩ = 63

*mf*

5 2

3

*mf*

A - gnus De - i, qui

A - gnus De - i, qui

A - gnus De - i, qui

8

tol - lis pec - cá - ta mun - di:

tol - lis pec - cá - ta mun - di:

tol - lis pec - cá - ta mun - di:

10

mi - se - ré - re no -

mi - se - ré - re no -

no -

4

13

bis. *mf* A-gnus De - i, qui

bis. *mf* A-gnus De - i, qui

bis.

16

pec - ta - mun - di:

tol - l - c - cá - ta - mun - di:

18

6

*mf*  
mi - se - ré - re no - bis.  
*mf*  
mi - se - ré - re no - bis.  
*mf*  
mi - se - ré - re no - bis.



Piano accompaniment for measures 18-20, featuring a treble and bass clef with various chords and melodic lines.

21

7



Piano accompaniment for measures 21-23, featuring a treble and bass clef with various chords and melodic lines.

24 8

*mf*  
A - gnus De - i, qui tol - lis pec - cá - ta  
*mf*  
A - gnus De - i, qui



Piano accompaniment for measures 24-25, featuring a treble and bass clef with a key signature of one sharp (F#).

26

tol - pec - ta mun - di:  
A - gnus De - i, qui tol - lis pec - cá - ta



Piano accompaniment for measures 26-27, featuring a treble and bass clef with a key signature of one sharp (F#).

28 9

Musical notation for measures 28 and 29. It consists of three staves: two treble clefs and one bass clef. The key signature has one sharp (F#). The notes are mostly whole and half notes, with some rests.

mun - - di:

Musical notation for measures 30 and 31. It consists of a grand staff (treble and bass clefs) and a separate bass clef staff below. The grand staff contains a melodic line with various accidentals and a harmonic accompaniment. The bass clef staff has a simple bass line.

30 10

Musical notation for measures 30 and 31. It consists of three staves: two treble clefs and one bass clef. The key signature has one sharp (F#). The notes are mostly quarter and eighth notes. Dynamics markings include *mf* and *p*.

do - na bis pa - cem, do - na no - bis

do - na no - bis pa - cem, do - na no - bis

do - na no - bis

Musical notation for measures 32 and 33. It consists of a grand staff (treble and bass clefs) and a separate bass clef staff below. The grand staff contains a melodic line with various accidentals and a harmonic accompaniment. The bass clef staff has a simple bass line.

33

11

pa - cem. *p*

pa - cem. *p*

pa - cem. *p*

*mf*

*pp*

35

Do - na no - bis

38

pa - - cem.  
Do - na no - bis pa - - cem.  
Do - na no - bis

42

*pp rall.*  
pa - cem.  
*pp*  
pa - cem.  
*pp*  
pa - cem, pa - cem.

## Registration d'orgue

### KYRIE

Manuels: fonds doux 8'  
Pédale: Bourdons 16', 8'  
Accouplements, Récit/Pédale

- [1]: les 2 mains au Récit
- [9]: les 2 mains au Grand Orgue, + GO/Péd
- [21]: + Anches Récit
- [26]: les 2 mains au Récit, - GO/Péd

### GLORIA

Récit: flûtes 8', 4'  
Grand orgue et Positif: fonds doux 8'  
Pédale: Bourdons 16', 8'  
Accouplements, tirasse GO

- [1]: les 2 mains au Récit
- [3]: les 2 mains au GO
- [11]: + Anches Récit

### CREDO

Récit: fonds 8', 4', 2', Anches 8', 4'  
Positif: flûte 8'  
Grand orgue: fonds 8', 4'  
Pédale: fonds 16', 8'  
Accouplements, Récit et Grand-Orgue/Pédale

- [1]: les 2 mains au GO
- [7]: main droite au Positif, main gauche au Récit (Gambe, Voix Céleste soli)
- [8]: les 2 mains au Récit (- Gambe, Voix Céleste, + fonds 8', 4'), - GO/Péd
- [9]: les 2 mains au GO, + GO/Péd
- [10]: Récit (+ Anches 8', 4')
- [13]: comme [7]
- [14]: comme [1]
- [16]: GO (+ Bourdon 16', Anches 8', 4')

Les 4 dernières mesures: TUTTI

### SANCTUS

Récit: Gambe 8'  
Positif: Clarinette 8'  
Grand orgue: Flûte 8'  
Pédale: Bourdons 16', 8'

- [1]: main gauche au Récit, main droite au GO
- [3]: main droite au Récit, main gauche au GO
- [4]: GO: + Principal
- [5]: Récit: + Anches

### BENEDICTUS

Positif: Flûte 8' seul  
Pédale: Bourdons 16', 8'

- [1]: les 2 mains au Positif
- [5]: main droite au Positif, main gauche au Récit
- [10]: comme le [5] du Sanctus
- [18]: Récit: fonds 8', Bourdons 16', 8'
- [19]: Récit: fonds 8', Bourdons 16', 8'
- [20]: Récit: fonds 8', Bourdons 16', 8'
- [21]: Récit: fonds 8', Bourdons 16', 8'
- [22]: Récit: fonds 8', Bourdons 16', 8'
- [23]: Récit: fonds 8', Bourdons 16', 8'
- [24]: Récit: fonds 8', Bourdons 16', 8'
- [25]: Récit: fonds 8', Bourdons 16', 8'
- [26]: Récit: fonds 8', Bourdons 16', 8'
- [27]: Récit: fonds 8', Bourdons 16', 8'
- [28]: Récit: fonds 8', Bourdons 16', 8'
- [29]: Récit: fonds 8', Bourdons 16', 8'
- [30]: Récit: fonds 8', Bourdons 16', 8'
- [31]: Récit: fonds 8', Bourdons 16', 8'
- [32]: Récit: fonds 8', Bourdons 16', 8'
- [33]: Récit: fonds 8', Bourdons 16', 8'
- [34]: Récit: fonds 8', Bourdons 16', 8'
- [35]: Récit: fonds 8', Bourdons 16', 8'
- [36]: Récit: fonds 8', Bourdons 16', 8'
- [37]: Récit: fonds 8', Bourdons 16', 8'
- [38]: Récit: fonds 8', Bourdons 16', 8'
- [39]: Récit: fonds 8', Bourdons 16', 8'
- [40]: Récit: fonds 8', Bourdons 16', 8'
- [41]: Récit: fonds 8', Bourdons 16', 8'
- [42]: Récit: fonds 8', Bourdons 16', 8'
- [43]: Récit: fonds 8', Bourdons 16', 8'
- [44]: Récit: fonds 8', Bourdons 16', 8'
- [45]: Récit: fonds 8', Bourdons 16', 8'
- [46]: Récit: fonds 8', Bourdons 16', 8'
- [47]: Récit: fonds 8', Bourdons 16', 8'
- [48]: Récit: fonds 8', Bourdons 16', 8'
- [49]: Récit: fonds 8', Bourdons 16', 8'
- [50]: Récit: fonds 8', Bourdons 16', 8'
- [51]: Récit: fonds 8', Bourdons 16', 8'
- [52]: Récit: fonds 8', Bourdons 16', 8'
- [53]: Récit: fonds 8', Bourdons 16', 8'
- [54]: Récit: fonds 8', Bourdons 16', 8'
- [55]: Récit: fonds 8', Bourdons 16', 8'
- [56]: Récit: fonds 8', Bourdons 16', 8'
- [57]: Récit: fonds 8', Bourdons 16', 8'
- [58]: Récit: fonds 8', Bourdons 16', 8'
- [59]: Récit: fonds 8', Bourdons 16', 8'
- [60]: Récit: fonds 8', Bourdons 16', 8'
- [61]: Récit: fonds 8', Bourdons 16', 8'
- [62]: Récit: fonds 8', Bourdons 16', 8'
- [63]: Récit: fonds 8', Bourdons 16', 8'
- [64]: Récit: fonds 8', Bourdons 16', 8'
- [65]: Récit: fonds 8', Bourdons 16', 8'
- [66]: Récit: fonds 8', Bourdons 16', 8'
- [67]: Récit: fonds 8', Bourdons 16', 8'
- [68]: Récit: fonds 8', Bourdons 16', 8'
- [69]: Récit: fonds 8', Bourdons 16', 8'
- [70]: Récit: fonds 8', Bourdons 16', 8'
- [71]: Récit: fonds 8', Bourdons 16', 8'
- [72]: Récit: fonds 8', Bourdons 16', 8'
- [73]: Récit: fonds 8', Bourdons 16', 8'
- [74]: Récit: fonds 8', Bourdons 16', 8'
- [75]: Récit: fonds 8', Bourdons 16', 8'
- [76]: Récit: fonds 8', Bourdons 16', 8'
- [77]: Récit: fonds 8', Bourdons 16', 8'
- [78]: Récit: fonds 8', Bourdons 16', 8'
- [79]: Récit: fonds 8', Bourdons 16', 8'
- [80]: Récit: fonds 8', Bourdons 16', 8'
- [81]: Récit: fonds 8', Bourdons 16', 8'
- [82]: Récit: fonds 8', Bourdons 16', 8'
- [83]: Récit: fonds 8', Bourdons 16', 8'
- [84]: Récit: fonds 8', Bourdons 16', 8'
- [85]: Récit: fonds 8', Bourdons 16', 8'
- [86]: Récit: fonds 8', Bourdons 16', 8'
- [87]: Récit: fonds 8', Bourdons 16', 8'
- [88]: Récit: fonds 8', Bourdons 16', 8'
- [89]: Récit: fonds 8', Bourdons 16', 8'
- [90]: Récit: fonds 8', Bourdons 16', 8'
- [91]: Récit: fonds 8', Bourdons 16', 8'
- [92]: Récit: fonds 8', Bourdons 16', 8'
- [93]: Récit: fonds 8', Bourdons 16', 8'
- [94]: Récit: fonds 8', Bourdons 16', 8'
- [95]: Récit: fonds 8', Bourdons 16', 8'
- [96]: Récit: fonds 8', Bourdons 16', 8'
- [97]: Récit: fonds 8', Bourdons 16', 8'
- [98]: Récit: fonds 8', Bourdons 16', 8'
- [99]: Récit: fonds 8', Bourdons 16', 8'

## Orgelregistrierung

### KYRIE

Manuale: sanfte Grundstimmen 8'  
Pedal: Subbass 16', Gedacktbass 8'  
Manualkoppel, Schwellwerk/Pedal

- [1]: beide Hände am Schwellwerk
- [9]: beide Hände am Hauptwerk, + HW/Ped
- [21]: + Zungen Schwellwerk
- [26]: beide Hände am Schwellwerk, - HW/Ped

### GLORIA

Schwellwerk: Flöten 8', 4'  
Hauptwerk und Positiv: sanfte Grundstimmen 8'  
Pedal: Subbass 16', Gedacktbass 8'  
Manualkoppeln, HW/Ped

- [1]: beide Hände am Schwellwerk
- [3]: beide Hände am Hauptwerk
- [11]: + Zungen Schwellwerk

### CREDO

Schwellwerk: Grundstimmen 8', 4', 2', Zungen 8', 4'  
Positiv: Flöte 8'  
Hauptwerk: Grundstimmen 8', 4'  
Pedal: Grundstimmen 16', 8'  
Manualkoppeln, Schwellw./Ped, HW/Ped

- [1]: beide Hände am HW
- [7]: rechte Hand am Positiv, linke Hand am Schwellwerk (Gambe, Vox Celestis soli)
- [8]: beide Hände am Schwellwerk (- Gambe, Vox Celestis, + Grundstimmen 8', 4') HW/Ped
- [9]: beide Hände am HW, + HW/Ped
- [10]: Schwellwerk (+ Zungen 8', 4')
- [13]: wie [7]
- [14]: wie [1]
- [16]: GO (+ Gedackt 16', Zungen 8', 4')

Die letzten 4 Takte: TUTTI

### SANCTUS

Schwellwerk: Gambe 8'  
Positiv: Klarinette 8'  
Hauptwerk: Flöte 8'  
Pedal: Subbass 16', Gedacktbass 8'

- [1]: linke Hand am Schwellwerk, rechte am HW
- [3]: rechte Hand am Schwellwerk, linke am HW
- [4]: GO: + Prinzipal 8', + Schw/HW und HW/Ped
- [5]: Schwellwerk: + Zungen 8', 4'

### BENEDICTUS

Positiv: Gedackt 8' solo  
Schwellwerk: Gambe 8', Vox Celestis

- [1]: beide Hände am Positiv
- [5]: beide Hände am Schwellwerk
- [7]: rechte Hand am Positiv, linke am Schwellwerk
- [12]: beide Hände am Schwellwerk
- [18]: wie [5] im Sanctus

### AGNUS DEI

Schwellwerk: Grundstimmen 8'  
Positiv: Gedackt 8'  
Hauptwerk: Flöte 8'  
Pedal: Subbass 16', Gedacktbass 8'  
Schwellw./HW

- [1]: beide Hände am Schwellwerk
- Takt 9: beide Hände am Positiv
- [4]: rechte Hand am HW, linke am Positiv
- [10]: beide Hände am Schwellwerk
- 1 Takt nach [11]: rechte Hand am Positiv, linke Hand am Schwellwerk

**Sologesang / Solo Voice**

Eberlin: Messa di San Giuseppe	91.304
Rheinberger: Missa puerorum op. 62 / auch chorisch	50.062
Telemann: Missa brevis in h TVVV 9:14 / Solo A (B)	⇨39.131

**Frauen- oder Kinderchor / Female and Children's Choir**

Bruckner: Choralmesse in C (Windhag) (auch solistisch)	40.759
Délibes: Messe brève	27.027
Fauré: Messe basse	40.705
Gounod: Messe brève no. 4 à la congrégation in C	27.024
Haydn, J. M.: Missa sub titulo Sancti Leopoldi MH 837	54.837
Lotti: Missa in a a 3 voci	40.662
Rheinberger: Messe in A op. 126 (2 Fassungen)	50.126
- Messe in Es „Reginae Sti. Rosarii“ op. 155	50.155
- Messe in g „Sincere in memoriam“ op. 187	50.187
Zimpel: Messa Olevanese	27.034

**Männerchor / Male Choir**

Gounod: Messe brève no. 5 aux séminaires in C	●40.831
- Messe no. 2 pour les sociétés chorales	27.022
Lotti: Missa in a a 3 voci	⇨40.830
Rheinberger: Messe in B op. 172 (2 Fassungen)	●50.172
- Messe in F op. 190	●50.190

**Gemischter Chor a cappella / Mixed Choir a cappella**

Bruckner: Messe ohne Gloria und Credo	40.141/60
- Messe für den Gründonnerstag	40.141/70
Doppelbauer: Missa brevis	92.035
Haydn, J. M.: Missa Sanctae Crucis MH 41	⇨50.312
Kalliwoda: Missa a 3 voci / Coro SAM	27.039
- Missa in a	27.026
Monteverdi: Missa in F	40.671
Palestrina: Missa ad fugam	1.609
- Missa Ave regina coelorum	27.013
- Missa Papae Marcelli	92.092
Rheinberger: Messe in d op. 83	50.083
- Messe in Es zu 2 Chören „Cantus Missae“ op. 109	●50.109
- Messe in F „In honorem Sanctissimae Trinitatis“ op. 117	50.117
- Messe in G „Sanctae Crucis“ op. 151	50.151
- Messe in a „Missa in omnium sanctorum“ op. 197	50.197
Scarlatti, D.: Missa brevis quatuor vocum	⇨40.616
Spohr: Messe in C op. 54	91.210
Swider: Missa minima	27.021
Vaughan Williams: Mass in g minor	40.653

**Gemischter Chor und Orgel / Mixed Choir and Organ**

Albrechtsberger: Missa in D	⇨40.639
Buxtehude: Missa brevis	36.020
Dvořák: Messe in D op. 86	●40.651
Fasch: Missa a 16	●27.083
Franck, C.: Missa in G	40.646/50
Frauenberger: Missa in G SAB	91.039
Gounod: Messe brève no. 7 aux chapelles	40.637
Haydn, J. M.: Missa pro Quadragesima	●40.654
- Missa pro Quadragesima MH 54	50.325
- Missa pro Quadragesima MH 55	50.326
Jancsó: Missa Angelis (Credo)	50.327
Langlaß: Missa Misericordiae B (SAB)	40.696
Liszt: Missa in G	27.016
Monteverdi: Missa in G	●40.647
- Missa in illo tempore	1.542
Mozart, L.: Missa in G KV 115	40.670
Palestrina/Bach: Missa brevis	40.642
Rheinberger: Messe in f op. 159	35.301
- Messe in E „Misericordias Domini“ op. 192	●50.159
Rossini: Petite Messe solennelle	50.192
Schnizer: Missa in C (mit obligater Orgel)	40.650
Schumann: Missa sacra op. 147 (arr)	●⇨40.649
Telemann: Missa brevis zum Osterfest TVVV 9:3	40.687/45
- Missa brevis zum Weihnachtsfest TVVV 9:5	39.098
	39.097

**Gemischter Chor und Streicher / Mixed Choir and Strings**

Caldara: Missa dolorosa in e, [Fg, 2 Trb]	40.680
- Missa in G	10.208
Eberlin: Missa brevis in a	27.042
Fischer, J. C. F.: Missa Sancti Dominici	⇨27.012
Haydn, J.: Missa brevis in F. Missa Nr. 1	40.601
- Missa brevis Sancti Joannis de Deo in B. Missa Nr. 7	40.600
Mozart: Missa brevis in G KV 49	40.621
- Missa brevis in d KV 65	40.622
- Missa brevis in G KV 140	40.623
- Missa brevis in F KV 192	●40.624
- Missa brevis in D KV 194	●40.625
- Missa brevis in B KV 275	40.629
Schubert: Messe in G, [2 Tr, Timp] D 167	●⇨40.675
- Messe in C, [2 Ob (Cl), 2 Tr, Timp] D 452	40.658

**Gemischter Chor und Orchester / Mixed Choir and Orchestra**

Bach, J. S.: Missa h-Moll BWV 232	●31.232
- Missa F-Dur BWV 233	31.233
- Missa A-Dur BWV 234	31.234
- Missa g-Moll BWV 235	31.235
- Missa G-Dur BWV 236	31.236
Beethoven: Messe in C op. 86	40.688
- Missa solennis op. 123	40.689
Biber: Missa Alleluja a 26	⇨40.679
- Missa Sancti Henrici	40.676
Cherubini: Krönungsmesse in G (1819)	40.087
Dvořák: Messe in D op. 86	40.653
Franck, C.: Messe in A op. 12	40.646
Hasse: Missa in d (1751)	⇨40.663
- Missa in g (1783)	●50.705
Haydn, J.: Missa in hon. BVM in Es. Missa Nr. 4 (Gr. Orgelsolom.)	40.603
- Missa Cellensis in hon. BVM in C. Missa Nr. 5 (Cäcilienmesse)	40.604
- Missa Sancti Nicolai in G. Missa Nr. 6	40.605
- Missa Cellensis in C. Missa Nr. 8 (Kleine Mariazeller Messe)	40.606
- Missa in tempore belli in C. Missa Nr. 9 (Paukenmesse)	40.607
- Missa St. Bernardi de Offida in B. Missa Nr. 10 (Heiligmesse)	40.608
- Missa in angustis in d. Missa Nr. 11 (Nelsonmesse)	40.609
- Missa in B. Missa Nr. 12 (Theresienmesse)	40.610
- Missa in B. Missa Nr. 13 (Schöpfungsmesse)	40.611
- Missa in B. Missa Nr. 14 (Harmoniemesse)	40.612
Haydn, J. M.: Missa Sanctae Ursulae MH 546	54.210
- Missa Sancti Hieronymi MH 254	54.211
- Missa Sancti Leopoldi MH 837	54.837
- Missa sub titulo Sanctae Theresiae MH 97	⇨50.318
- Missa sub titulo Sancti Francisci aphan. MH 826	50.329
- Missa Sancti Joannis Nepomuceni MH 18	50.314
Heinichen: Missa (Nr. 9) in D	27.048
Herzogenberg: Messe in e op.	27.020
Holzbauer: Missa in C	⇨50.501
Hummel: Messe in G KV 77	40.664
- Messe in C KV 61	40.613
- Waisenhausmesse in C KV 139	40.614
- Trinitatismesse in C KV 14	40.615
- Spatzenmesse in C KV 220	40.626
- Credomesse in C KV 257	40.616
- Missa in C KV 258	40.627
- Orgelsolomesse in C KV 259	40.628
- Missa longa in C KV 262	51.262
- Krönungsmesse in C KV 317	40.618
- Messe in C KV 337	40.619
- Messe in C KV 427 (Levin)	51.427
Nicolai: Messe in D	27.036
Puccini: Missa a 4 voci („Messa di Gloria“)	40.645
Rheinberger: Messe in C op. 169	50.169
Richter: Messe in C	●⇨40.648
Ristori: Weihnachtsmesse	27.044
Rossini: Messa di Rimini (1809)	40.674
Ryba: Missa pastoralis bohemia	40.678
- Missa pastoralis in C	⇨40.683
Schiedermayr: Pastoralmesse	27.069
Schindler: Missa in Jazz	27.028
Schubert: Messe in F D 105	40.656
- Messe in G D 167 (Fassung Klosterneuburg)	●⇨40.675
- Messe in G D 167 (Fassung Ferdinand Schubert)	40.643
- Messe in B D 324	40.657
- Messe in C D 452	40.658
- Messe in As D 678	40.659
- Messe in Es D 950	40.660
Zelenka: Missa Gratias agimus tibi ZWV 13	⇨40.644

**Requiem-Vertonungen / Requiem settings**

Campra: Requiem	21.004
Cherubini: Requiem in c	40.086
Fauré: Requiem (Letztfassung, 1900)	27.312
- Requiem (Version für kleines Orchester, 1889)	27.311
García: Requiem in d (1816)	23.008
Gounod: Messe funèbre	27.090
- Requiem in C op. posth.	27.315
Haydn, J. M.: Requiem in c MH 154	50.321
Kraus: Requiem VB 1	50.663
Lachner, Fr.: Requiem in f op. 146	27.301
Mozart: Requiem KV 626 (Süßmayr+Levin)	51.626, 51.626/50
Rheinberger: Requiem in b op. 60	50.060
- Requiem in Es op. 84	50.084
- Requiem in d op. 194	●50.194
Suppé: Missa pro defunctis	40.085
Verdi: Messa da Requiem	27.303
- Messa da Requiem (reduzierte Fassung)	27.303/50

● = auf/on Carus CD    ⇨ = Erstausgabe/first edition  
 (:): Alternativbesetzungen/alternative scoring, [:]: ad libitum