

Max REGER

I. Sonate fis-moll op. 33

herausgegeben von / edited by
Alexander Becker, Christopher Grafschmidt,
Stefan König und Stefanie Steiner-Grage

Einzelausgabe aus der / Separate edition from
Reger-Werkausgabe
Abteilung I: Orgelwerke
Band 2: Phantasien und Fugen,
Variationen, Sonaten, Suiten I

Editionsleitung / Editorial Directors:
Susanne Popp und Thomas Seedorf

Für Vorwort und Kritischen Bericht verweisen wir auf den
Band der Werkausgabe sowie die zugehörige DVD.
Die DVD ist auch separat erhältlich.

For Foreword and Critical Report please refer to the volume
from the Werkausgabe and the respective DVD.
The DVD is also available separately.

Herrn Prof. A.W. Gottschalg, großherz. sächs. Hoforganisten,
in verehrungsvoller Dankbarkeit gewidmet

I. Sonate fis-moll

für Orgel

Opus 33 (1899)

I. Phantasie

Max Reger
1873–1916

Allegro energico

Manuale

I. Man **ff** 8', 4', 2' ohne 16'

Pedal 8', 16', 4' **ff**

4

+ C III

+ C III

cresc.

cresc.

7

più f

più f + 16' etc.

10

sempre poco a poco cre - - scen - - - do Org Pl

+ 32'

sempre poco a poco cre - - scen - - - do Org Pl

13 *ri - tar - dan - do* **Un poco meno mosso** II. Man *pp* 8'

III. Man *pp* 8', 4'

18

22

poco a poco di *ppp*

ri - - tar - - dan - - do

- 8', nur 16'

ppp

* Так аsierungen der Takte 15-16, 18 und 21 siehe Kritischer Bericht. / For the phra

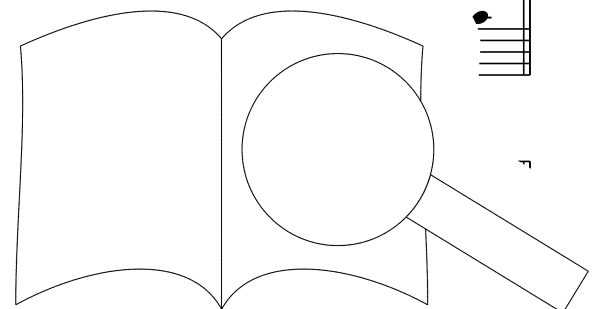

Tempo primo (Allegro energico)

25 III. Man *mf* 3 3

II. Man *mf* 3 3

8', 16', 4' *marcato, ma legato* *mf*

Un poco più mosso

27 I. Man *f marcato, ma ben legato*

a poco cre - - scen - -

+ C III

Più allegro

31 do strin - - gen

2 2

33

sempre *cre - - - - - scen - - -*

+ C II

35

do *+ 16'* *più f*

2 *(legato)*

più f

37

Più mosso

più f + C II

3 *sempre poco a poco*

+ C I

più f

3 *sempre poco a poco*

39

cre *scen* *do*

scen

41

fff *sempre poco a poco cre - - - - -*

Pedal *alle Register*

fff

43

poco a poco ri - - tar - - dan - - do al tempo

scen - - - - -

poco a poco ri - - tar - - dan - - do tempo rimo

45

Org Pl

Org Pl

(Org Pl) *ritardando*

46

a temp *tar - - dan - - do*

PROBENPARTIUR

Ausgabequalität gegenüber Original evtl. gemindert • Evaluation Copy - Quality may be reduced • Carus-Verlag

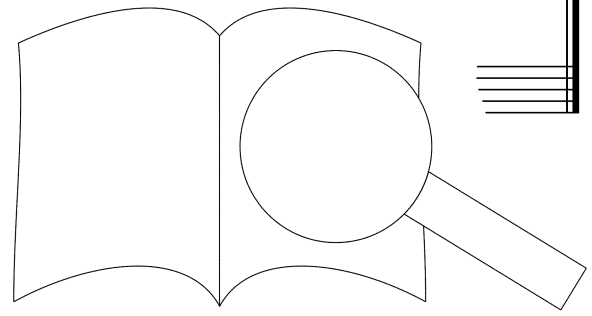

II. Intermezzo

Sostenuto

II. Man 8' (etwas hervortretend)

Musical score for the first system, measures 1-3. It features three staves: a grand staff (treble and bass clefs) and a separate bass clef staff. The key signature is one sharp (F#) and the time signature is 3/4. The first staff has a dynamic marking of *p*. The second staff has a dynamic marking of *p* and includes the instruction "III. Man 8', 4'" and a trill. The third staff has a dynamic marking of *p* and includes the instruction "16', 8'".

Musical score for the second system, measures 4-6. It features three staves. The first staff has a dynamic marking of *p* and includes the instruction "più *p*". The second staff has a dynamic marking of *p* and includes the instruction "più *p*". The third staff has a dynamic marking of *p* and includes the instruction "più *p*". The first staff also includes the instruction "poco a poco *sf*".

Musical score for the third system, measures 7-9. It features three staves. The first staff has a dynamic marking of *pp* and includes the instruction "al tempo". The second staff has a dynamic marking of *pp*. The third staff has a dynamic marking of *pp*. The lyrics "gen - - - do ri - tar - dan - do" are written above the first staff.

Musical score for the fourth system, measures 10-12. It features three staves. The first staff has a dynamic marking of *pp* and includes the instruction "più *pp* ma sempre 8'". The second staff has a dynamic marking of *pp* and includes the instruction "più *pp* ma sempre 8', 4'". The third staff has a dynamic marking of *pp* and includes the instruction "più *pp*".

14 un poco strin - - gen - - do ri - tar - dan - do al tempo primo

17

più pp

pppp III. Man nur Äoline 8'

pp

Più andante

II. Man *f* 8', 4'

8', 16', 4' (etwas hervortreten)

f

24

I. Man *f* 8', 16', 4' (etwas hervortretend)

+ 2'

tr

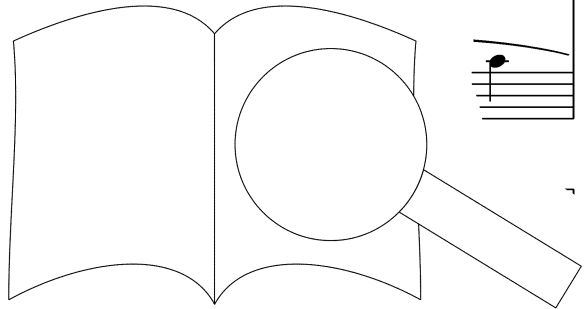

PROBEPARTITUR
 Ausgabequalität gegenüber Original evtl. gemindert • Evaluation Copy - Quality may be reduced • Carus-Verlag

Un poco mosso

(II. Man)

sempre poco a poco

26 + 16'

(I. Man)

29 *strin* *gen*

+ C III

pù f

+ C II

pù f

31 Allegro

I. Man *pù f* + C III

sempre

gen

do

Più mosso

33

+ C I

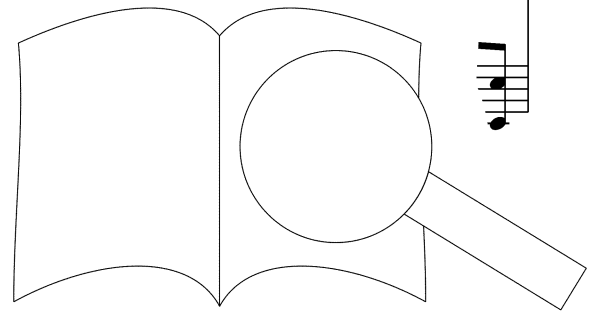
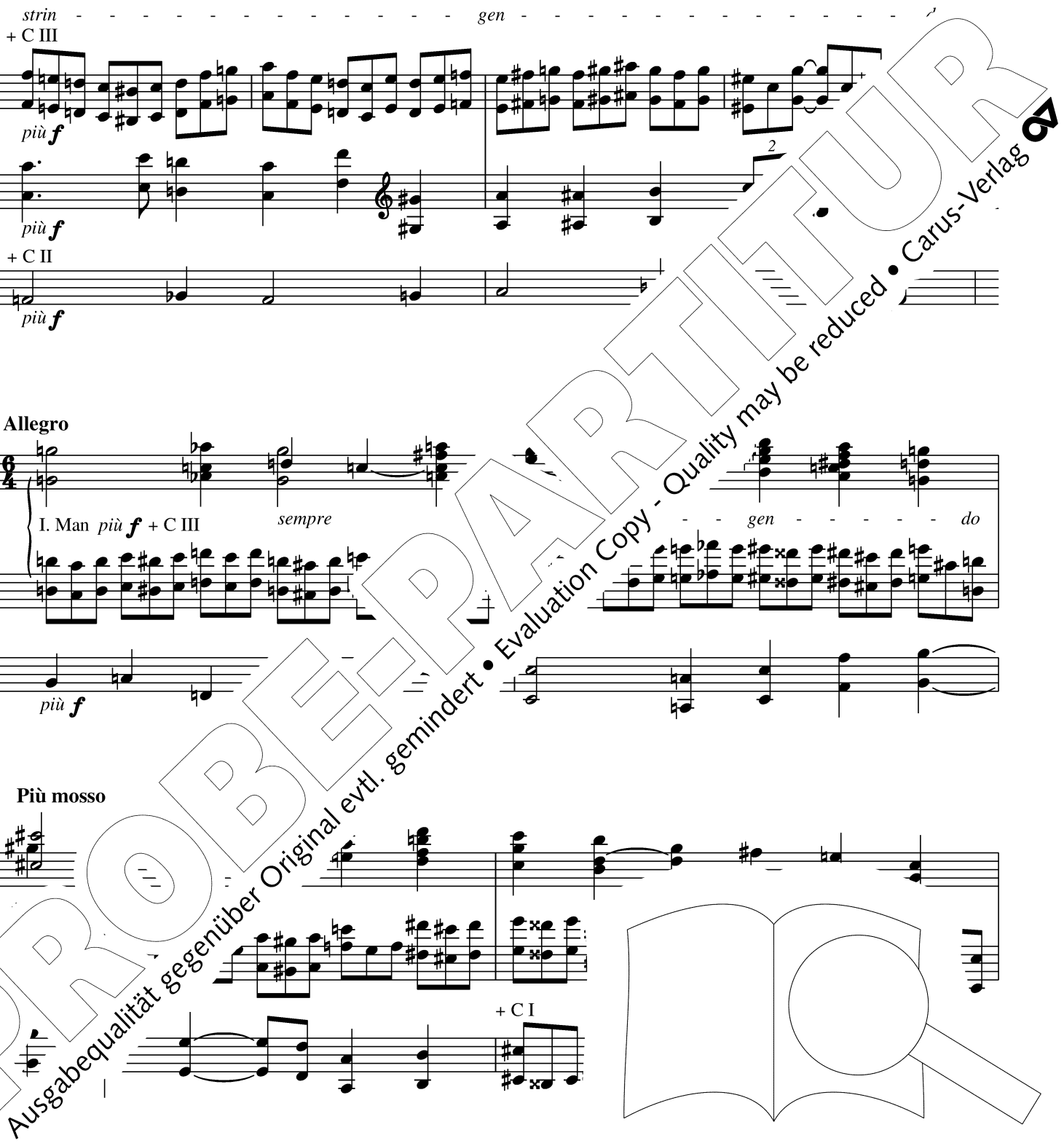

35

più ff e sempre cre

+ 32'

più ff

37

II. Man III. Man *poco a poco ri - - tar -*

scen - - do Org Pl (I. Man) *poco a poco*

(etwas hervortret)

- C I - C II

mi - - -

40

dan - - - do *m. etwa.*

nu - - en - - do *pp*

nu - - -

pp 16'

44

III. Man - 4'

di - - - mi

pppp

di - - - mi

III. Passacaglia

Andante con moto

Musical score for the first system, measures 1-8. The score is in G major (one sharp) and 3/4 time. It features a grand staff with treble and bass clefs. The right hand has rests for the first seven measures, with a final measure containing a triplet of eighth notes. The left hand plays a steady eighth-note accompaniment. Dynamics include *ppp* at the beginning and end of the system. A rehearsal mark 'III. Man 8', 4'' is placed above the final measure of the right hand.

Musical score for the second system, measures 9-14. The right hand begins with a melodic line of eighth notes, while the left hand continues with the eighth-note accompaniment. A rehearsal mark '9' is placed above the first measure of the right hand.

Musical score for the third system, measures 15-20. This system introduces two different fingering options for the right hand: 'II. Man *pp* 8'' and '(III. Man 8', 4')'. The left hand continues with the accompaniment. The dynamic marking is 'un poco meno *ppp*'. A rehearsal mark '15' is placed above the first measure of the right hand.

Musical score for the fourth system, measures 21-24. The right hand continues with the melodic line, and the left hand with the accompaniment. A rehearsal mark '21' is placed above the first measure of the right hand. The dynamic marking is '(II. Man) *pp*'. A large watermark 'PROBEEPARTITUR' is overlaid diagonally across the page.

26

poco a poco cre - - -

poco a poco cre - - -

31

scen - - - do

II. Man 8', 4'

sempre poco a poco cre

mf

scen - - - do

se

35

scen

scen - - -

38

an)

4'

PROBEEPARTEI FÜR

Ausgabequalität gegenüber Original evtl. gemindert • Evaluation Copy - Quality may be reduced • Carus-Verlag

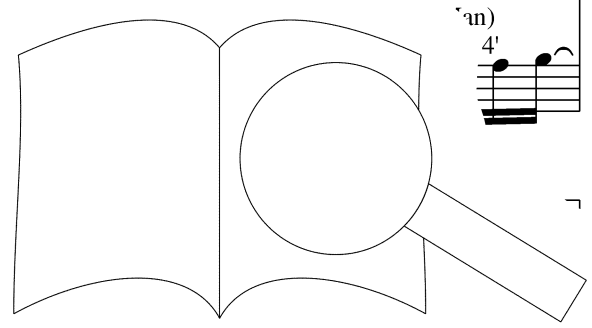

41

I. Man 8', (ohne 4')

44

+ 16'

più f

+ 2'

più f

47

più f

50

tr

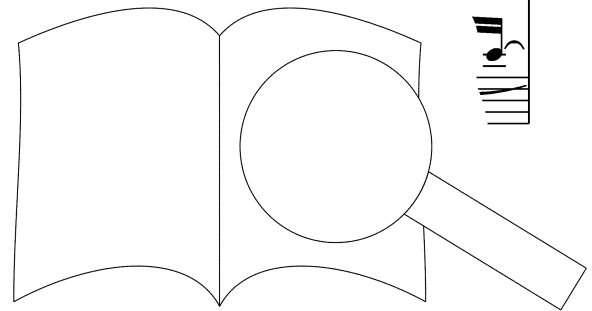

53

56

+ 2' (I. Man)

più ff

II. Man

+ C III, alle Register im III. Man

+ C II

più ff

59

a

im II. Man

+ C I

+ 32'

62

(II. Man) 8'

3

C III]

PROBEPARTITUR
 Ausgabequalität gegenüber Original evtl. gemindert • Evaluation Copy - Quality may be reduced • Carus-Verlag

65 III. Man *p* 8', 4'

sempre poco a poco di - - mi - - - -

sempre poco a poco di - - mi - - - -

69 (III Man)

nu - - - - en

nu - - - - en

pp

73

78

II. Man 8'

più pp

III. Man (8', 4')

più pp

+ 4'

Die T... zeichen vom entsprechenden Abschnitt der Erstschrift grundlegend ab, ...
 in ... ks neu komponierte; siehe Kritischer Bericht und DVD, Anhang 1. / Mm. 7:
 je Reger newly composed both variations in question for the first edition; see t

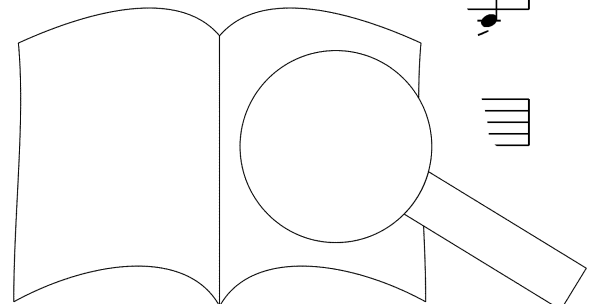

83 - 4'

III. Man (8', 4')

più ppp

II. Man (8')

più ppp

sempre di - - mi - - un -

più ppp *sempre* di - - mi - - un -

87

II. Man alle Register

pppp *ff*

I. Man Trompete 8', Oktave 4' etc.

pppp *ff*

en - - - - do

en - - - - do *pppp* *ff*

+ C III

91

95

+ C III, III. Man alle Register

più ff

+ Posaune

più ff

+ C II 3

più ff

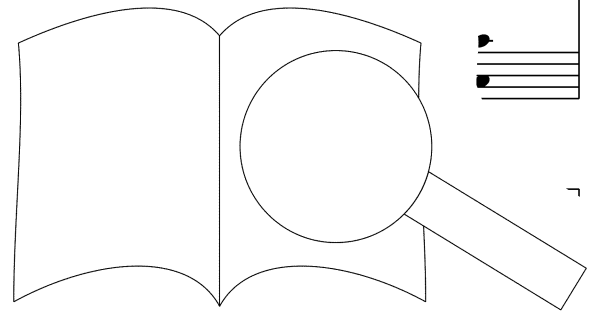

PROBEEPARTIUR

Ausgabequalität gegenüber Original evtl. gemindert • Evaluation Copy - Quality may be reduced • Carus-Verlag

99

103

I. Man (ohne C II, III)
fff - Trompete 8',
- Posaune 16'

+ C I
trmm

106

+ C III

109

112

più ff
+ C II

3

3

+ 32'

più ff

115

118

II. Man (C III)

III. Man

- C I, II, III, - 32'

121

sempre

poco

a

sempre

poco

a

PROBEPARTITUR

Ausgabequalität gegenüber Original evtl. gemindert • Evaluation Copy - Quality may be reduced • Carus-Verlag

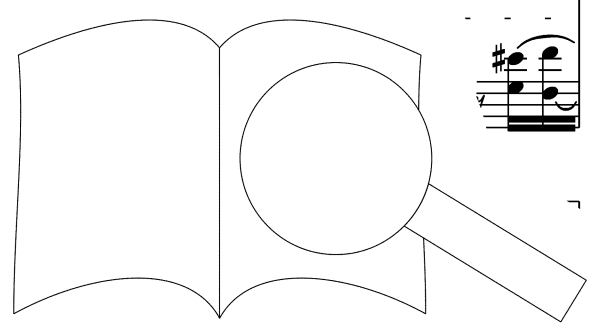

124

nu - - - - - en - - - - - do

nu - - - - - en - - - - - do

127

pp *fff* I. Man

pp *fff* + C II, III

129

pp *fff* I. M. II. Man

131

pp *fff* I. Man II Man

133

I. Man II. Man

135

I. Man *più fff* II. Man

+ C I

più fff

137

II. Man I. Man I. Man II. Man I. Man

140

I. Man II. Man I. Man

PROBEPARTITUR

Ausgabequalität gegenüber Original evtl. gemindert • Evaluation Copy - Quality may be reduced • Carus-Verlag

143

III. Man 8', 4'

II. Man

meno f

8', 4', 16' [- C III]

(II. Man)

- C I

meno f

- C II

145

sempre poco a poco di

- C III

sempre poco a r

147

mi

nu

mi

nu

149

151

do

III. Man
pp

più pp

più pp

- 4'

do

pp

più pp

più pp

156

do

pppp

I. Man *fff* ohne C II, III

ohne C I, II, III

pppp

fff

162

do

+ C II

cre

+ C I

sempre *cre*

166

do

scen

Org Pl

1

159 einen des Erstdrucks komponierte Reger für Karl Straube fünf Variationen, Anhang 2. / After publication of the first edition, Reger composed five variations.

PROBE-PARTITUR - Evaluation Copy - Quality may be reduced - Carus-Verlag

PROBE-PARTITUR
Ausgabequalität gegenüber Original evtl. gemindert • Evaluation Copy - Quality may be reduced • Carus-Verlag 

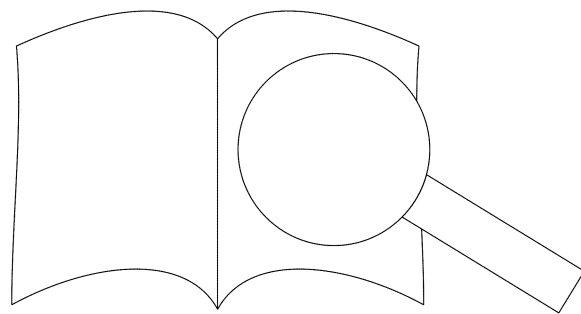

PROBE-PARTITUR
Ausgabequalität gegenüber Original evtl. gemindert • Evaluation Copy - Quality may be reduced • Carus-Verlag 