

Rainer

Große-Gaune-Kanons

20 neue vierstimmige T.

mit Begleitung von
Klavier, Baß und

zum Musi
und im

Partitur

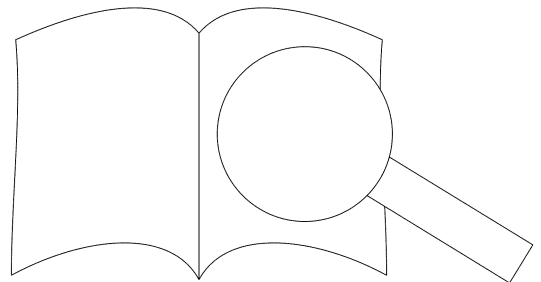

Car

Ausgabequalität gegenüber Original evtl. gemindert • Evaluation Copy - Quality may be reduced • Carus-Verlag

PROBE-PARTITUR

PROBE-PARTITUR
Ausgabequalität gegenüber Original evtl. gemindert • Evaluation Copy - Quality may be reduced • Carus-Verlag 

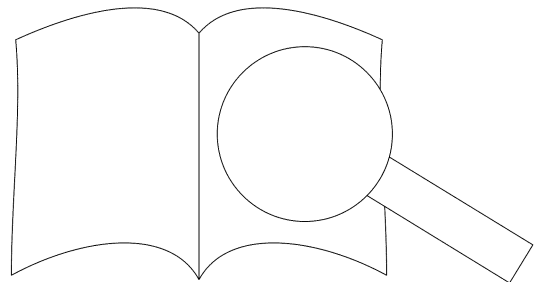

Inhalt

1. Trauermarsch (Märsch)	5
2. ...-Mourrée (Medium Fox / Jive)	6
3. ...-Sarabande – Sarabande / Folia ...-Walzer	8
4. ...-Holidays (Calypso)	10
5. Rosarot (Reggae)	12
6. Dschungel-Schwüle (Reggae Shuffle)	14
7. Sonnenbrand (Cha Cha Cha)	
8. Rumbastunde	
9. Urwald-Samba	
10. Gaudeamus hodie	22
11. Come on and ...	24
12. Der kleine ...	26
13. Gr...ien ...	28
14. ...	30
...	32
... (Tango)	34
... (Foxtrott)	36
...winging Lips (Quickstep)	38
19. Rolling – (Blues)	40
20. Fast Food (Zweifacher)	42

Zum Au
Chorpar
CV 12.9
und 6 S!

Öffentli
Postfach
Regel dt
und Kirche...deckt.

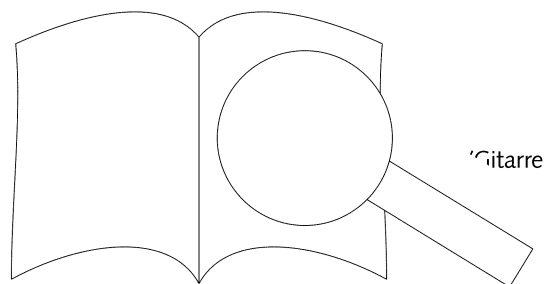

Gitarre

Illustrati... Jürgen Massatsch
Cover: Max Ackermann (1887–1975)
© MAA, Bietigheim-Bissingen

Vorwort

Die vorliegenden Kanons entstanden für den Gebrauch in Schulhören sowie im schulischen Musikunterricht beider Sekundarstufen. Sie orientieren sich allesamt an verschiedenen Tanztypen, an solchen des Barock oder des karibischen Raumes genauso wie an Standard- und lateinamerikanischen Tänzen. Bewegung und Tanzschritte dazu also erwünscht.

Alle Kanons sind sowohl a cappella als auch Rhythmusgruppe oder beidem ausführbar. Sie sind so gehalten, daß sie von Schulmusikern gespielt werden können. Die Kanons können auch unter Auslassung des vierten Stimmes dreistimmig a cappella gesungen werden. Beispiele sind Gaudeamus hodie und Fast Food, aber auch Geigen in Wien und Swinging Lips.

Zuletzt sei hier noch darauf hingewiesen, wie sich verschiedene Teile des Lehrstoffes für den Musikunterricht durch diese Kanons vermitteln lassen.

- Rhythmus:
- Robins Sarabande, Fast Food, Geigen in Wien
 - Come on and sing, Summer-Holidays, Urwald-Tänze
 - Gaudeamus hodie, Swinging Lips
 - Beispiele: Gute Laune, Rolling

- Tonraum:
- Durtonleiter: Summer-Holidays (Klavier), Dschungel-Schwüle (Klavier)
 - harmonische Molltonleiter: Tango-Jimmy, Mürli
 - Chromatik: Gute Laune, Geigen in Wien, Rolling (Intro)
 - blue notes: Rolling (auch Klavier)

- Intervalle:
- klein, groß, vermindert, übermoll

- Harmonik:
- Leitereigene Akkorde
 - übermäßiger Dreiklang
 - Paralleltonart: Bachs Bourrée
 - Kadenz: Reggae, Summer-Holidays, Gute Laune
 - Halbschlüssel: Robins Sarabande
 - Trugschlüssel: Dschungel-Schwüle
 - Dominante: Dschungel-Schwüle, Come on and sing
 - Subdominante: Swinging Lips, Rumbastunde, Come on and sing
 - Quartakkord: Rumbastunde
 - Sextakkord: Dschungel-Schwüle, Rumbastunde

- Intervallarten:
- Chromatische Umkehrung: Bachs Bourrée
 - Sequenz: Robins Sarabande
 - Viertonnote: Gute Laune
 - Quart-Vorhalt: Bachs Bourrée
 - Quartsext-Vorhalt: Gaudeamus hodie, Fast Food

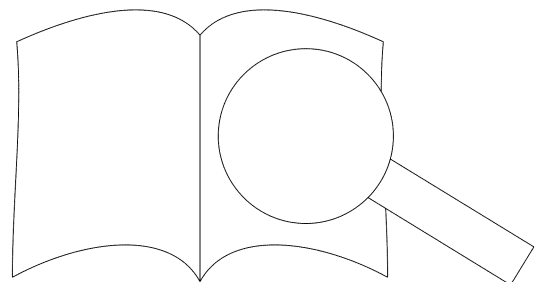

1 Traumland

Air (Ballade) nach Johann Pachelbel

11d Satz: Rainer Butz

1. $\text{♩} = 60$ G D Em Hm C G Am D⁷ Hm Am G C D⁷

m, m, m, m, ...

2. 5 G D Em Hm C G Am D⁷ G Hm Am G C D⁷

nü, nü, nü, nü, ...

3. 9 G D G Am D⁷ Em D⁷ G Hm Am

nü, nü, nü, nü

Em Hm C G Am D⁷ Em D⁷ m D⁷

nü, nü, nü, nü, ...

Klavier Intro

arpeggio

Hi

rimshot

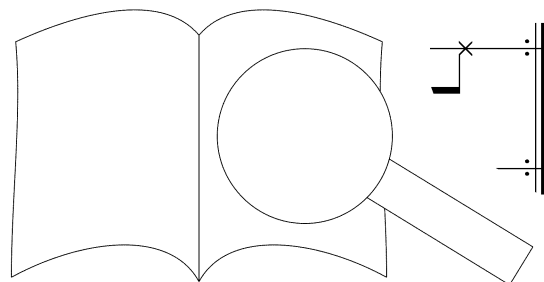

2 Bachs Bourrée

Bourrée (Medium Fox / Jive) nach Johann Sebastian Bach

Not und Satz: Rainer Butz

♩ = 144 1.

Hm Fis Hm A⁷ D Fis⁷



Da ba da, da ba da, da ba da, da ba da, da ba da, da ba

4 Fis^{sus4} Fis⁷ Fis Hm Fis Hm A⁷ D



da a du bi dum dum dum dum dum dum dum d a du bi

3. Fis⁷ Hm Fis Hm A⁷

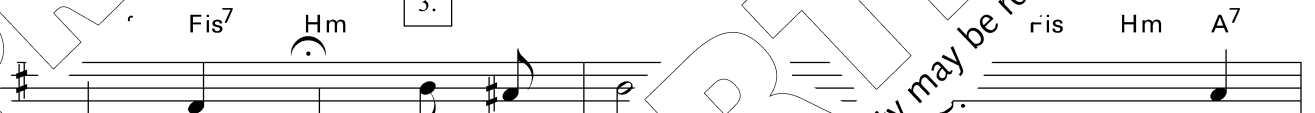

dum dum dum. Ding i dong ding

11 D Fis⁷ 4. Fis



dong ding i dong i schu-wi-du-wi-da, schu-wi-

14 H Fis D Fis⁷ Fis^{sus4} Fis⁷ Hm



da, schu-wi-du, schu-wi-da.

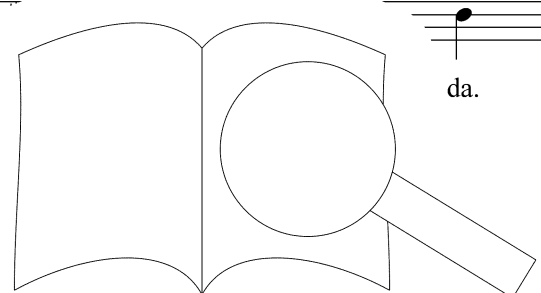

Intro

Kanon

Klavier

Musical notation for the piano introduction, featuring treble and bass staves with chords and a melodic line.

Musical notation for the piano canon, featuring treble and bass staves with chords and a melodic line.

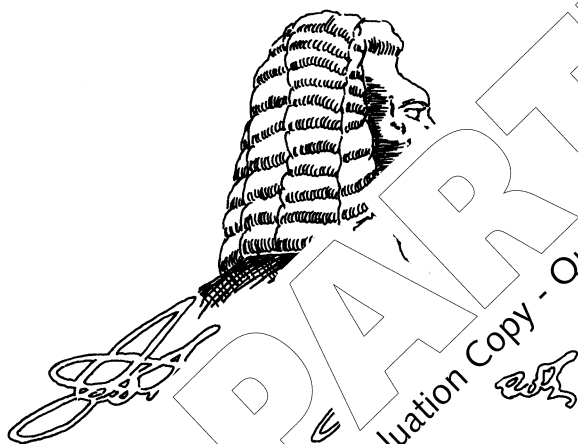

Hi Hat

Snare

Musical notation for Hi Hat and Snare drums, including a 'cl.' (crescendo) marking and an 'offen' (open) marking.

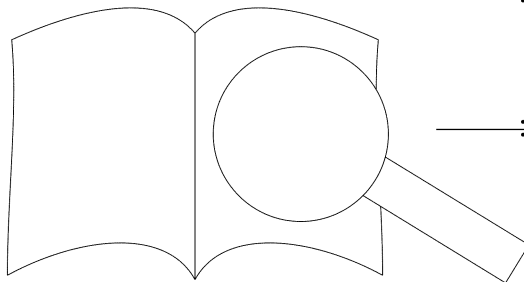

PROBE-PARTITUR
 Ausgabequalität gegenüber Original evtl. gemindert • Evaluation Copy - Quality may be reduced • Carus-Verlag

3 Robins Sarabande

nach Art der Folia (Langsamer Walzer)

und Musik: Rainer Butz

1. $\text{♩} = 96$ Gm D C⁷ F

Im Wald von Sher - ver - steckt lebt - Sir Hood,

5 B F Gm Cm D⁷

oh - ne Fehl , del, tief im Herz von A

2. 9 Gm D Gm C⁷

Bo - gen spannt, fürch - tet mar

1 F D⁷ Gm

Lau - ert hin - ter grü - nen Ei - chen, doch die Rei - chen.

3. 17 Gm D F

Und im Traum - dem Baum die La - dy

21 B Gm Cm D⁷

Ma - lö - nen, ach so star - ken Räu - ber steh'n. Je - der

4. 25 Gr D Gm C⁷ F

Ziel ge - nau, da - für Dar - um

F D⁷ Gm

-nem je - mals es ge - lingt, daß im Kampf

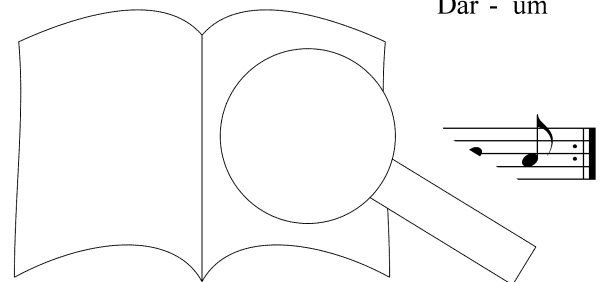

Intro

Klavier

The first system of the piano introduction consists of two staves. The right hand (treble clef) plays a sequence of chords and single notes: a G4-F4 dyad, a G4-F4-E4 triad, a G4-F4-E4-D4 tetrad, and a G4-F4-E4-D4-C4 pentad. The left hand (bass clef) plays a simple bass line: G2, F2, E2, D2, C2, B1, A1, G1.

The second system continues the piano introduction. The right hand plays: G4-F4-E4, G4-F4-E4-D4, G4-F4-E4-D4-C4, and G4-F4-E4-D4-C4. The left hand continues the bass line: G1, F1, E1, D1, C1, B0, A0, G0.

The third system features a more complex texture. The right hand has a melodic line: G4, F4, E4, D4, C4, B3, A3, G3. The left hand has a bass line: G2, F2, E2, D2, C2, B1, A1, G1. There are some accidentals and dynamics markings.

The fourth system continues the piano introduction. The right hand has a melodic line: G4, F4, E4, D4, C4, B3, A3, G3. The left hand has a bass line: G2, F2, E2, D2, C2, B1, A1, G1. There are some accidentals and dynamics markings.

Schellenkr

The Schellenkr part consists of a single staff with a treble clef. It contains a few notes: G4, F4, E4, D4, C4, B3, A3, G3. There are some accidentals and dynamics markings.

Tom-1

The Tom-1 part consists of a single staff with a treble clef. It contains a few notes: G4, F4, E4, D4, C4, B3, A3, G3. There are some accidentals and dynamics markings.

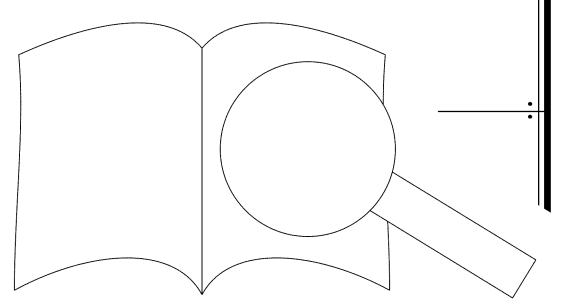

4 Summer-Holidays

Calypso

and Musik: Rainer Butz

1. $\text{♩} = 138$ C

Ev - 'ry - bod - y likes sun - n. ev - 'ry - bod - y likes fun,

2. G⁷ C

ev - 'ry - bo - - co - nuts_ and the fine Ca - rib - be - an

3. F⁶ G⁷ C

stay la - in - un -

F⁶ G⁷

Can you hear_ our_ song_ drum? And all to - geth - er:

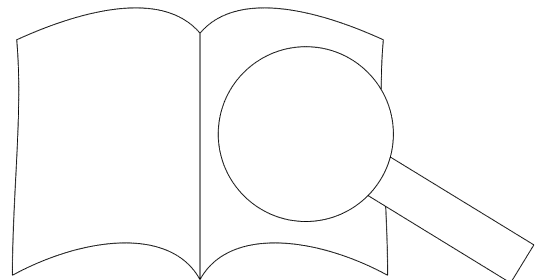

Intro

Klavier

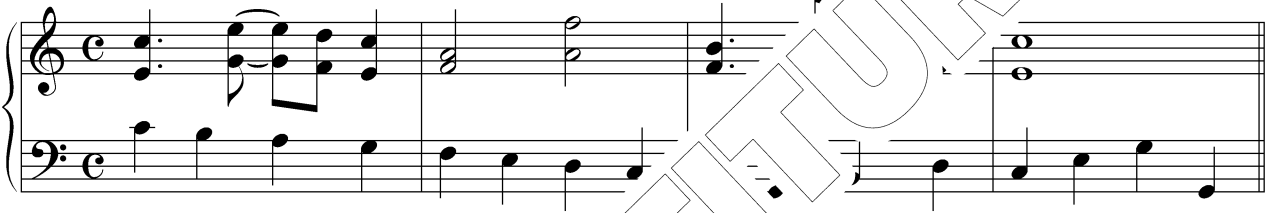

1.

2. Fine

G.

Maraca / Cabasa

Cowbell

Schellenkranz

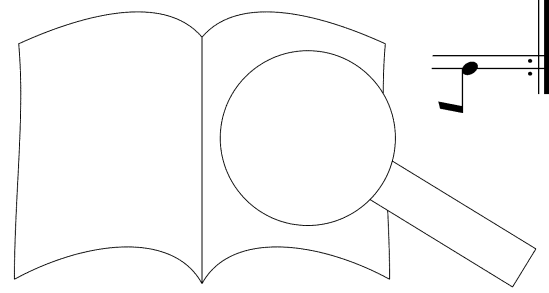

PROBEE-PARTITUR

Ausgabequalität gegenüber Original evtl. gemindert • Evaluation Copy - Quality may be reduced • Carus-Verlag

5 Rosarot

Reggae

Text und Musik: Rainer Butz

$\text{♩} = 86$

1.

Du, du, du, du, — — — — — lie-be dei-ne Au-gen zu, — — — — —

— — — — — da, da, d' — — — — — Träu-men ist so wun-der - bar. — — — — —

2.

— — — — — den Tag, die Zeit, — — — — — und — — — — — d Streit, — — — — —

— — — — — laß die See-le in den Raum, — — — — — in dei-nen Traum. — — — — —

3.

Du, du, du, d' — — — — — gen zu, — — — — — da, da, — — — — —

— — — — — da, — — — — — Träu-men ist so wun-der-wun-der-wun-der-wun-der - — — — — —

4.

— — — — — giß die Zeit — — — — —

— — — — — laß die See-le in den Raum, — — — — —

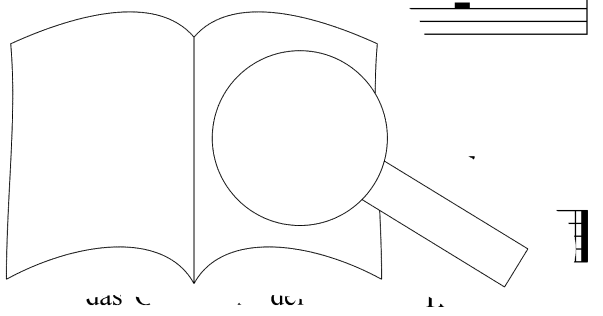

Intro Kanon

Klavier

Claves

Congas

Klatschen

Ride-Becken

Snare

6 Dschungel-Schwüle

Reggae Shuffle

and Musik: Rainer Butz

Moderate Swing (♩ = 3/4)

1. $\text{♩} = 90$

C Em7 C Em7

Hoch im Baum hängt das Faul- rö-te wan - dert durch das Laub oh-ne Hast, a-ber

2.

Gm7 G Am7 Dm7 C Em7

oh - ne aus-zu-ri schlan - ge win-det lang - sam sich zwi-schen

8 Gm7 C Em7 Am7 Dm7

te, feuch-te Gras. Sieh, die Gi - raf - an zar - ten

4. G C Em7 Am7 D m7 G

Zwei-gen hoch im Wind. Und dort qu der Pfüt - ze ba-den geht.



Moderate Swing (♩♩ = $\frac{1}{3}$ ♩)

Intro

Klavier

Kanon

Maraca / Chicken Shake

Schellenkranz

Kastagnetten

Snare

P

Ausgabequalität gegenüber Original evtl. gemindert • Evaluation Copy - Quality may be reduced • Carus-Verlag

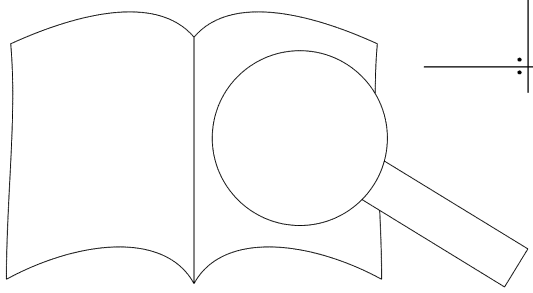

7 Sonnenbrand

Cha Cha Cha

Text und Musik: Rainer Butz

$\text{♩} = 132$ 1.

B F7

Son-ne und Meer_ und wei-ßer -l- Sand, sind auf der Welt_ in je-dem

4 B Es⁶

Land wohl-be-ke -ße Tou-ri - sten-scha-ren und auch Nu-d:

7 B/F B 2. B

i - rien-pa-ra - dies, ganz ge-wiß. I ge. - ten

B B/F F7

in Hän-ge - mat - ten, tee, und al-le

16 B 3. B B

schau'n: wer wird braun? Men-s -ben-blind, oh-ne Not pur-pur-rot.

21 B/F F7 B

Zeim Pool, Son-nen - brand? Un - be - kannt!

25 F7 B

zu Haus

Es⁶ B/F

Nichts - tun_ im Sinn: das nen is. .. Cha - na.

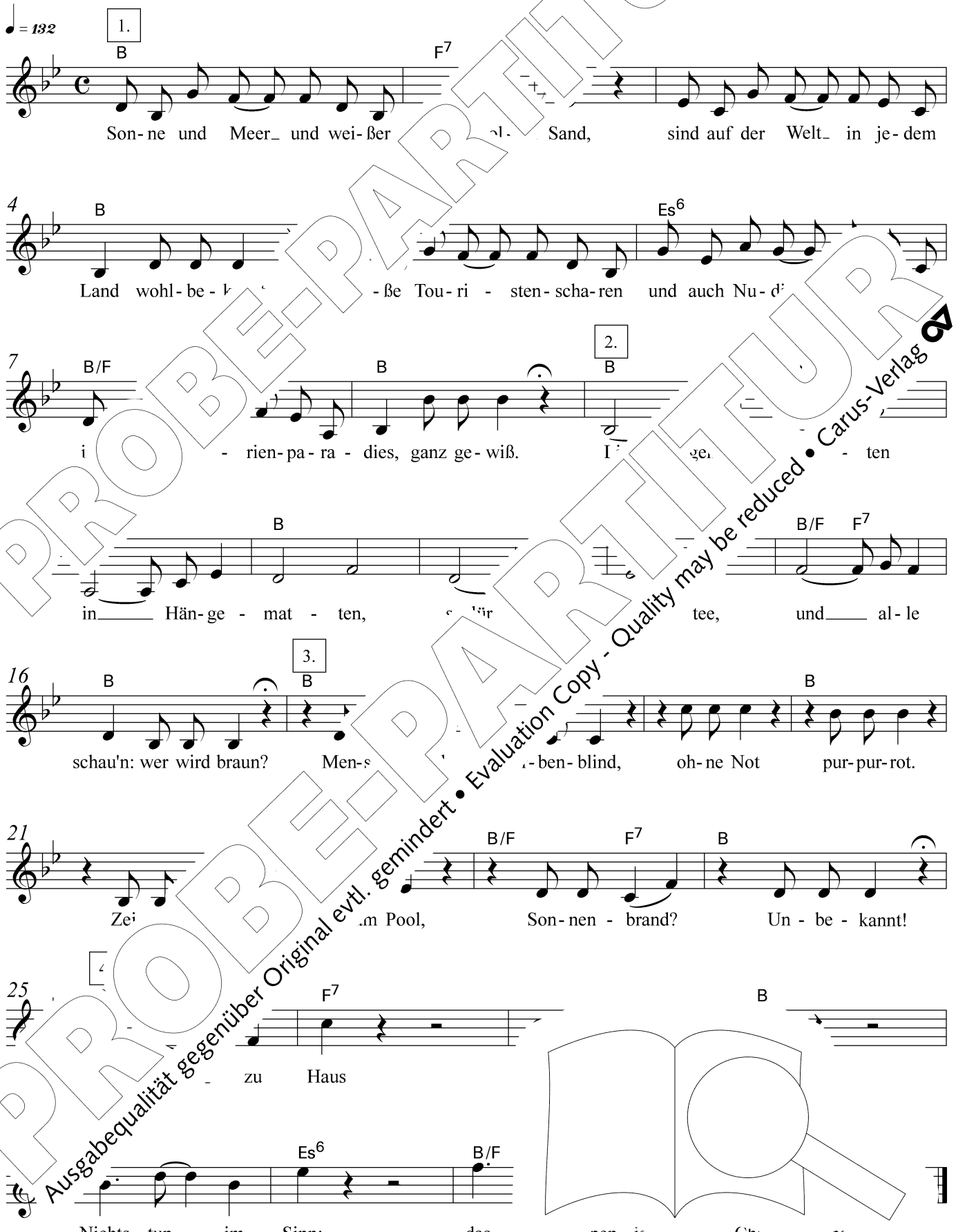

Intro

Klavier

Claves

Guiro

Maraca /
Cabasa

Cowbell

Bongr

Bass dru.

8 Rumbastunde

Rumba

Text und Musik: Rainer Butz

$\text{♩} = 112$

1. Cm Fm^7 Cm

Hörst du den Rum - ba - ln - gen von weit,

5 Des/F Fm^6 G^7 Cm

dann gibt es .r- an: ma - che dich be - reit!

9 2. Fm^7 G

uß, Rück, Seit, Schluß, da - nach in - de.

13 Fm^6 G^7

Tanz nicht zu schnell und tritt nicht Part - ners Wa - de.

17 3. Fm^7 Cm

Schau, schau mit bei - g - als und die Ar - me hal - te in die

21 Des/F Fm^6 G^7 Cm

Höh. cher - lich Ap - plaus von den Herrn und Da - men in der

25 Fm^7 G Cm

ie Paa - re an,

Fm^6

Ein je - des hat E - lan,

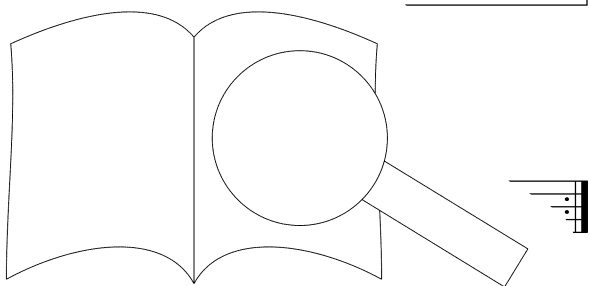

Intro

Klavier

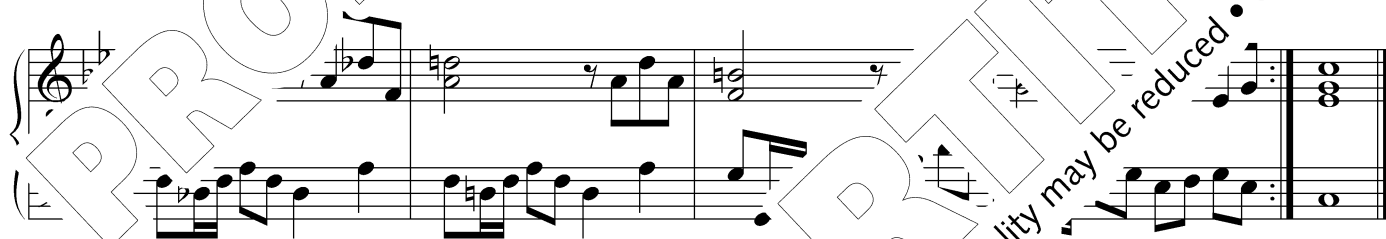
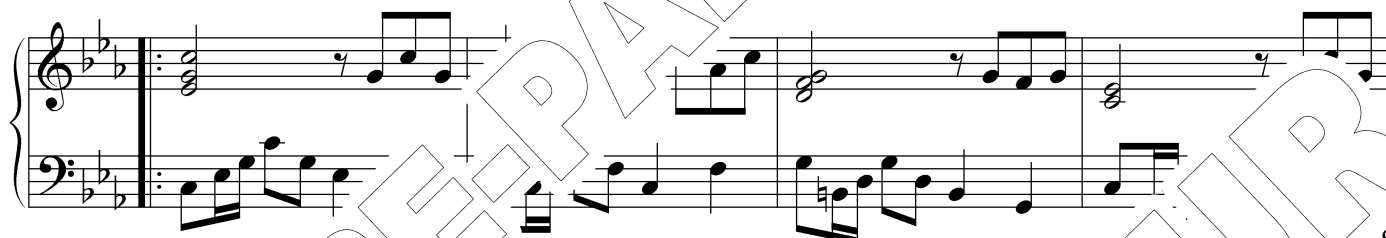
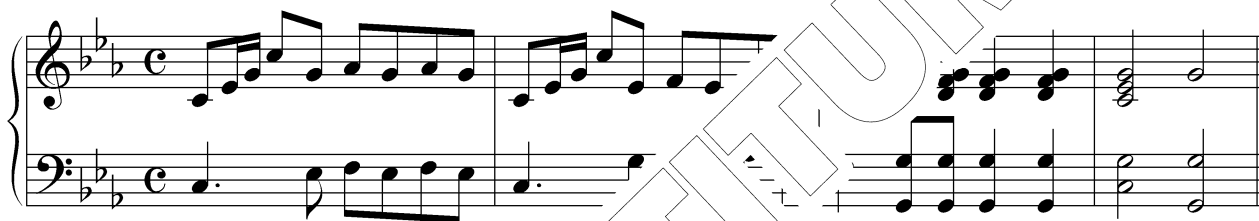

Claves

Maraca /
Cabasa

Bongos

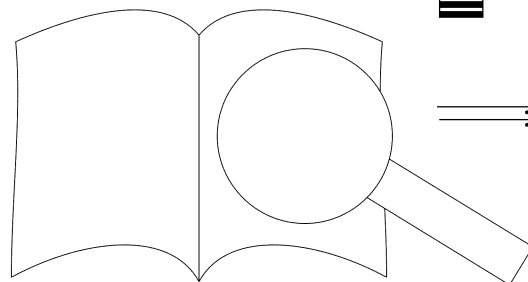
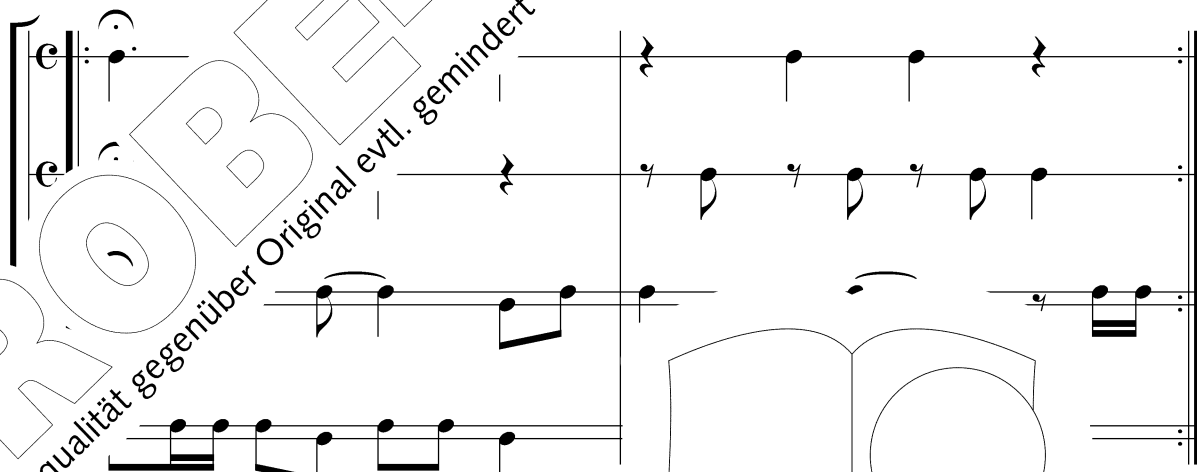

9 Urwald-Samba

Samba

Text und Musik: Rainer Butz

$\text{♩} = 100$

1.
D



Hö - ren Af - fen die - sen sin - gen sie da - zu ein Lied, -

5



sin - gen es ir D' Moll, - und al - le fin - den das su - r

9

2.



bei im Ge - äst, - weil sich so b



sprin - gen hin und sprin - gen her: -



tanz der Bär. - Sie

17

3.



bie - gen



gnü - gen, - der O - rang

21



U



schon ganz matt, weil - zu lan - ge Ar - me er hat. -

25

4

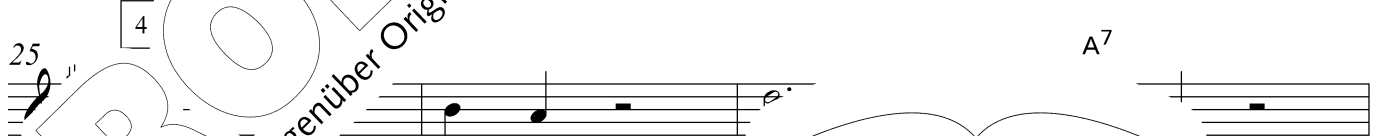

Go - ril - las,

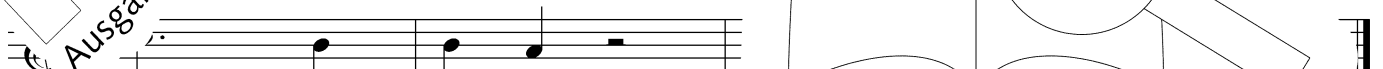

wol - len rok - ken,

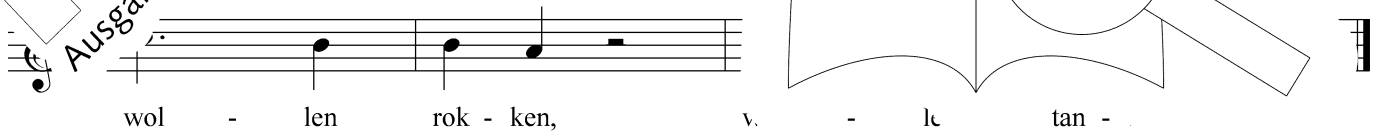

v. - lc tan -

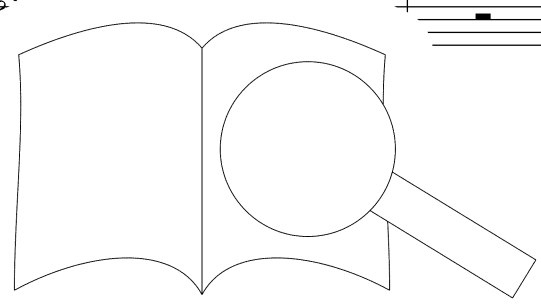

Intro

Klavier

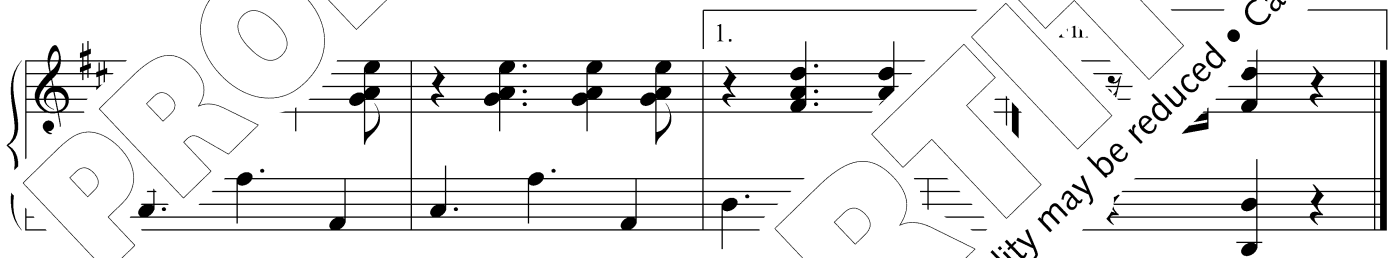
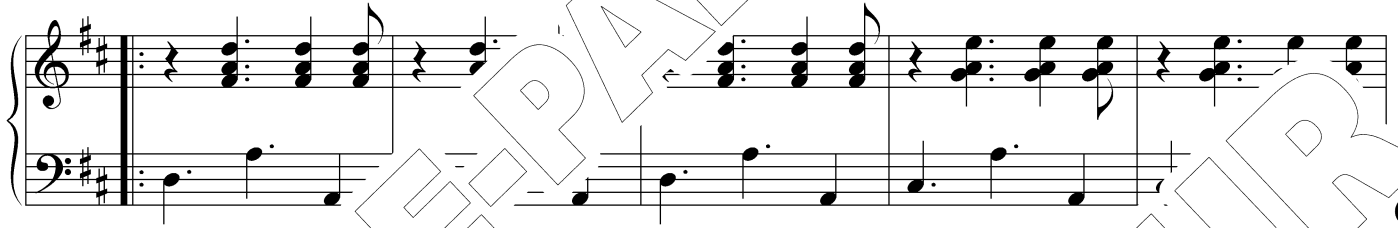
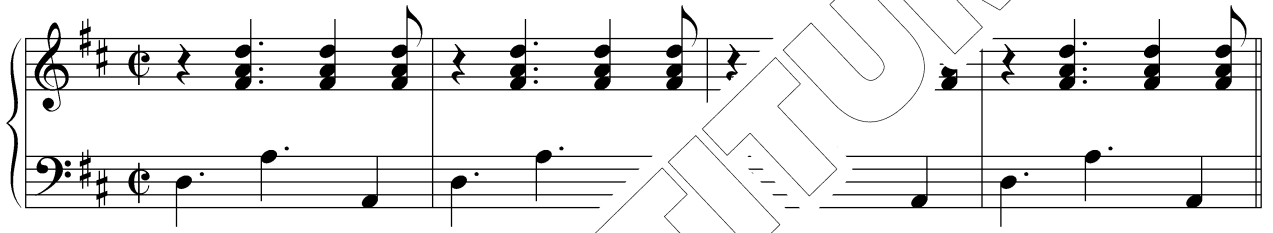

Maraca /
Chicken Shake

Agogo

Schellenk*

Tom-

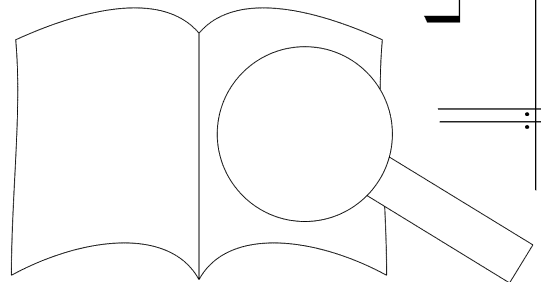
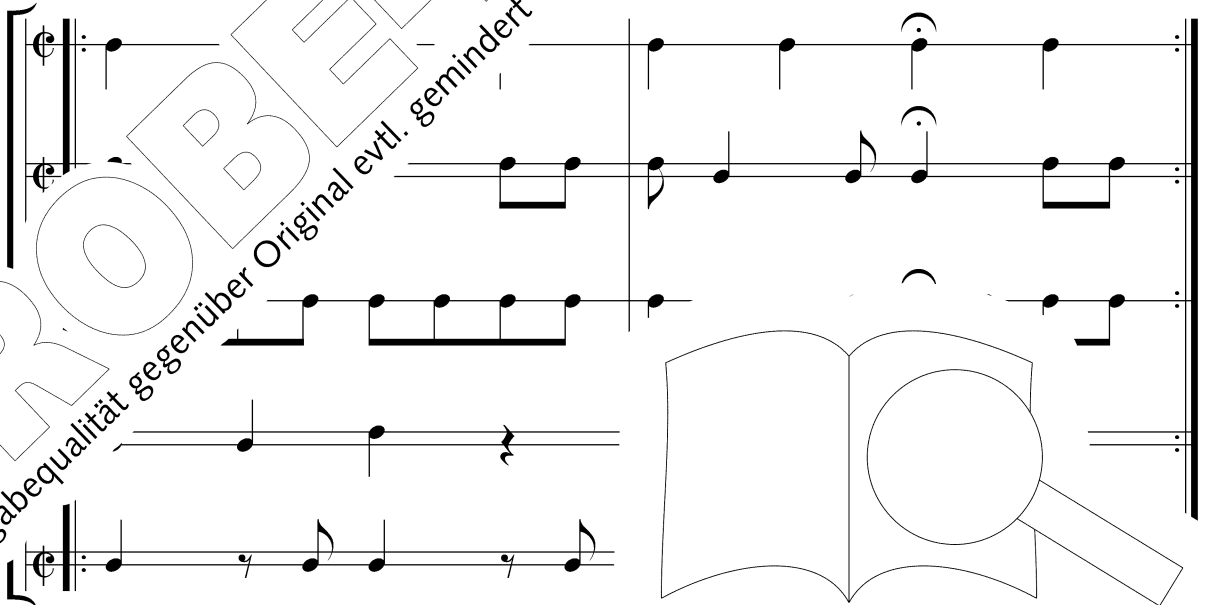

10 Gaudeamus hodie

Merengue

nach mdl. Überlieferung
Satz: Rainer Butz

1. $\text{♩} = 96$
C G^{7sus4} G⁷

Gau - de - a - mus, gau - de - a - de - a - mus ho - di - e.

5 C F⁶ C/G G C

Gau - de - a - r de - a - mus ho - di

9 2. 4 C

Gau a - mus, gau - de

6 F⁶ C/G

au - de - a - mus di - e.

17 3. G^{7sus4} C C F⁶

Gau - de - a gau - de -

23 C/G G 4. G^{7sus4}

a - mus Gau - de - a - mus,

27 C G⁷ C

- mus ho - di - e. de -

6 C/G

a - mus ho

e.

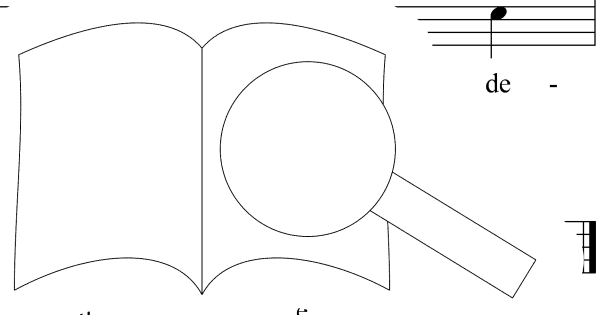

PROBE-PARTITUR
Ausgabequalität gegenüber Original evtl. gemindert • Evaluation Copy - Quality may be reduced • Carus-Verlag

Intro

Klavier

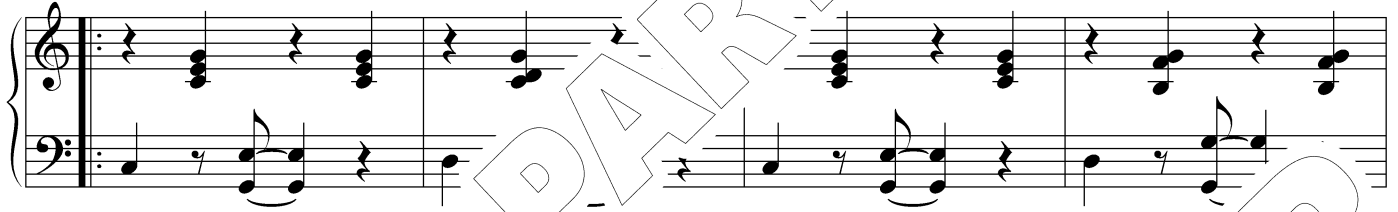
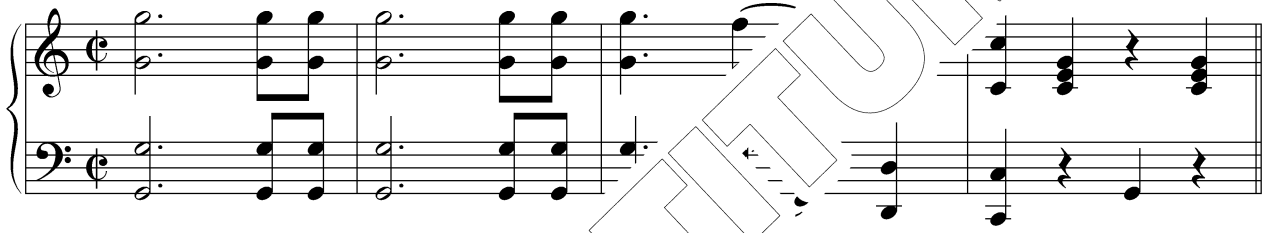

Mara
Cant.

Ausgabequalität gegenüber Original evtl. gemindert • Evaluation Copy - Quality may be reduced • Carus-Verlag

Tom-Tot.

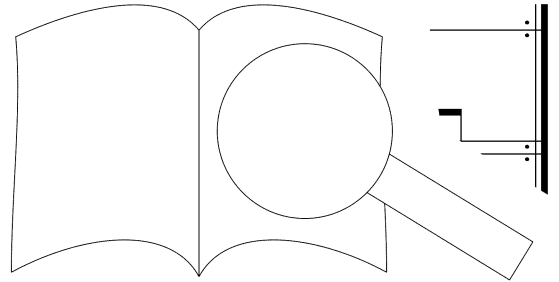
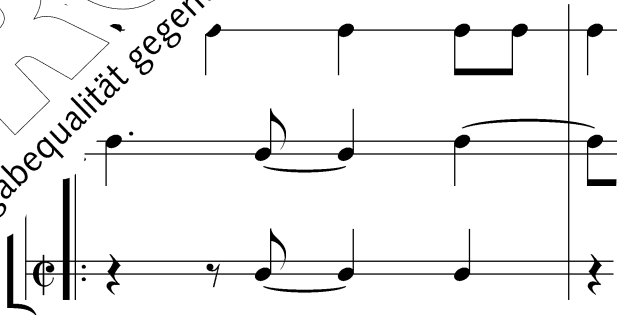

11 Come on and sing

Medium Fox / Jive

nach trad. Überlieferung
Text und Satz: Rainer Butz

♩ = 160

1. C7 F B⁶ F B⁺ C7 G7

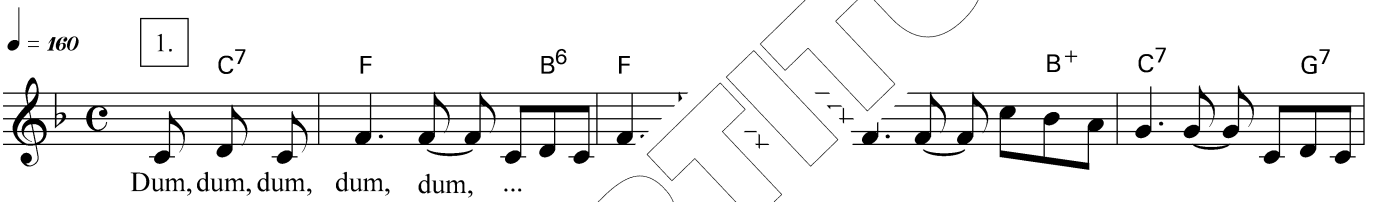

Dum, dum, dum, dum, dum, ...

5 C7 G⁺ G7 C7 C7 F C7

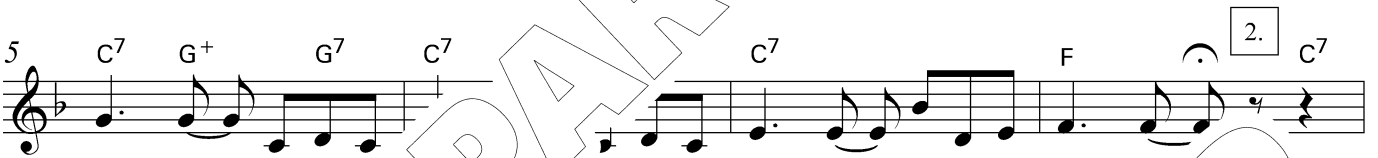

9 F B⁶ F B⁺

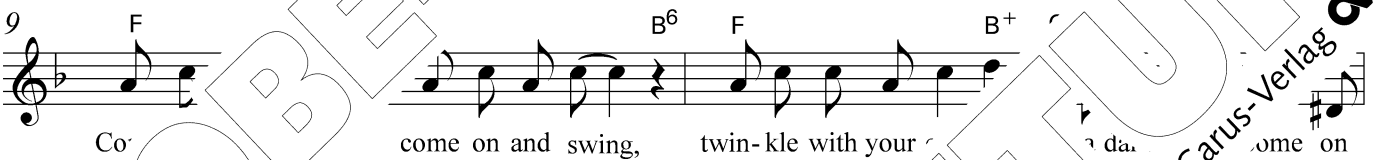

Co: come on and swing, twin- kle with your ... da. ... come on

11 G⁺ G7 C7 G⁺

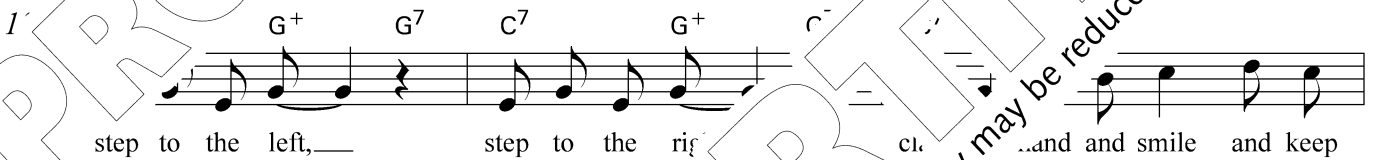

step to the left, step to the right, cl... and and smile and keep

16 F C7 F B⁶ F B⁺



danc - ing all night. Ba - dan. dam, ba - dan, dam, dam,

20 C7 G7 G⁺ G7 C7 F C7

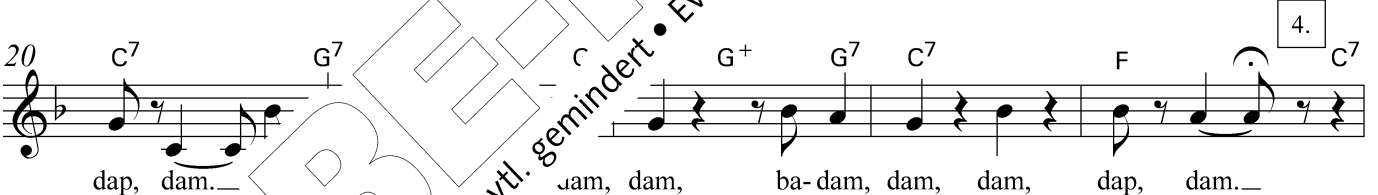

dap, dam. Jam, dam, ba - dan, dam, dam, dap, dam.

25 F B⁶ F B⁺ C7 G7

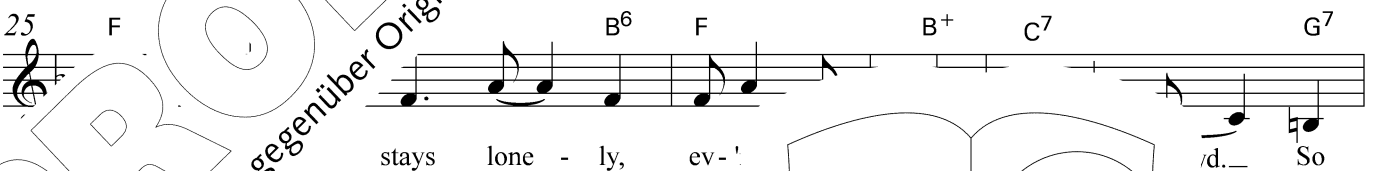

stays lone - ly, ev - ... /d. So

G⁺ G7 C7 G⁺ G7 C7

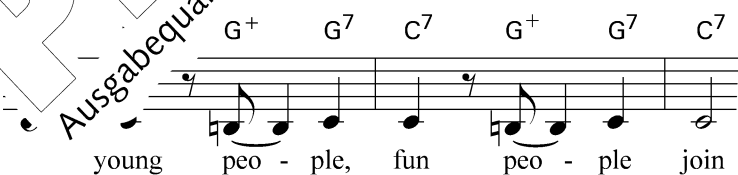

young peo - ple, fun peo - ple join

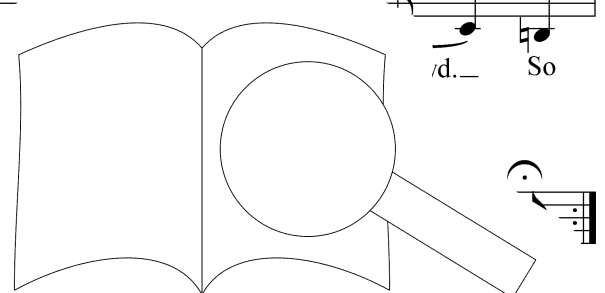

PROBEPARTITUR
 Original evtl. gemindert • Evaluation Copy - Quality may be reduced • Carus-Verlag

Intro

Kanon

Two staves of piano notation. The top staff is in treble clef and the bottom in bass clef. The key signature has one flat (B-flat). The time signature is common time (C). The introduction consists of 8 measures of rhythmic accompaniment. The canon section starts at measure 9 and continues for 4 measures.

Two staves of piano accompaniment notation. The top staff is in treble clef and the bottom in bass clef. The key signature has one flat. The time signature is common time. This section consists of 8 measures of accompaniment.

Two staves of piano accompaniment notation. The top staff is in treble clef and the bottom in bass clef. The key signature has one flat. The time signature is common time. This section consists of 8 measures of accompaniment, ending with a first ending bracket labeled '1.'.

Klatschen

Intro

Clapping notation for the introduction. It consists of 8 measures of rhythmic notation on a single staff, starting with a common time signature.

Klatschen

Clapping notation for the main section. It consists of 8 measures of rhythmic notation on a single staff, starting with a common time signature.

Hi Hat

Hi Hat notation for the main section. It consists of 8 measures of rhythmic notation on a single staff, starting with a common time signature. The word 'offen' is written above the final measure.

Ba.

Bass drum notation for the main section. It consists of 8 measures of rhythmic notation on a single staff, starting with a common time signature.

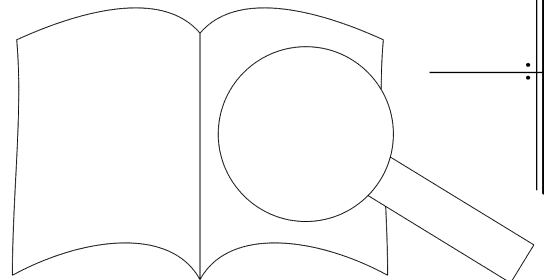

PROBEPARTITUR
 Ausgabqualität gegenüber Original evtl. gemindert • Evaluation Copy - Quality may be reduced • Carus-Verlag

12 Der kleine Zirkus

Slowfox

und Musik: Rainer Butz

Medium Swing (♩ = $\frac{1}{3}$)

♩ = 120

1. F Dm G⁷ C⁷

Du, — du, du, du, du, — u. — Der klei-ne Zir-kus hält — heut' in der

2. F B G⁷ G⁷

5 Stadt. Kommt a hin, da gibt es was zu seh'n von Ti-gern, Lö-we

3. F Dm B

9 die Ar-ti-sten hoch im Zir-kus - zelt, — own in der A -

4. C⁷ F Dm B G⁷ C⁷

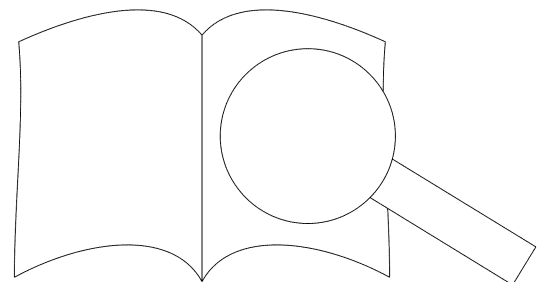

re - na. — Sen - sa - ti Mil - lio - nen.



Medium Swing (♩♩ = $\frac{1}{3}$ ♩)

Intro

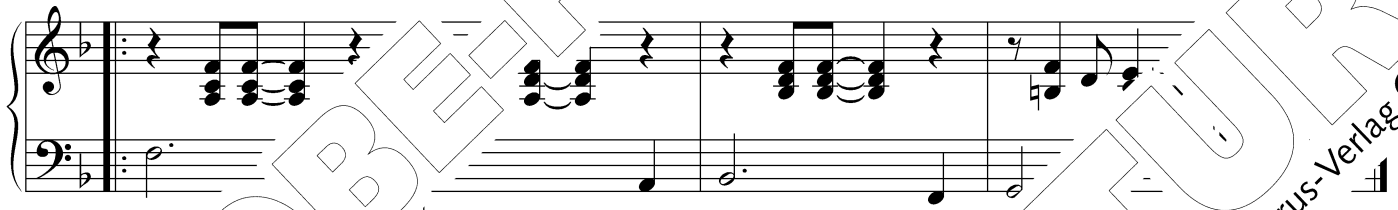
Klavier



Schellenkranz

Bongos

Hi Hat

Snare

Original evtl. gemindert • Evaluation Copy - Quality may be reduced • Carus-Verlag

♩♩ = $\frac{1}{3}$ ♩

ot

.narrsaiten

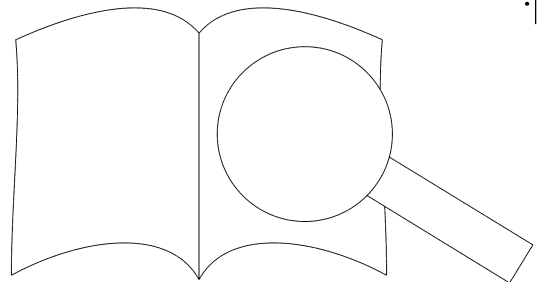
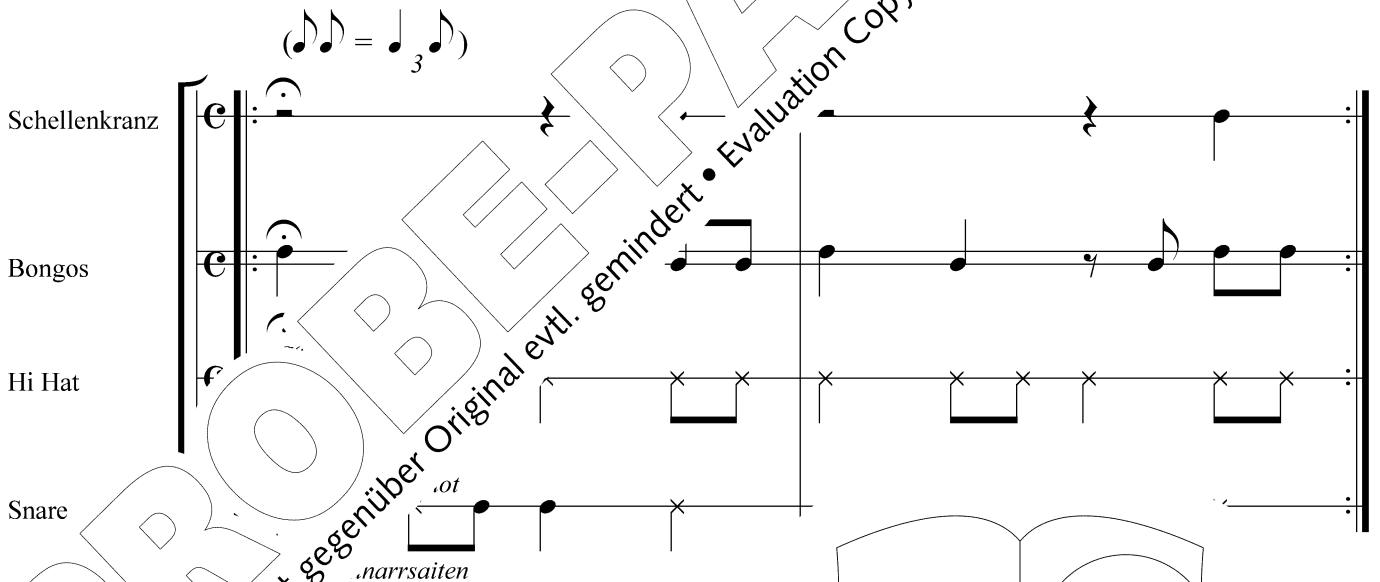

13 Geigen in Wien

Wiener Walzer

and Musik: Rainer Butz

♩ = 180

1. C

Dum, dum, dum, dum, dum, dum, dum,

9 G⁷ C
dum, dum, i, dum, dum, dum, dum,

17 2. Dm
dum. Gei- gen ringt ins Ohr, schmei- chelnd sanft gen

26 G⁷
, bald be - gehr - lich, strei - chen der kühl.

3. Dm
Gei - gen in Wien, nu - klin - gen so,

41 C
schwe - bend und süß ist ihr Ton.

49 4.
Ja, da - Ja, das gibt es nur in Wien. Ja, das gibt es nur in Wien.

55 D-
im Wal - zer drin. Al - les li s liegt im

G⁷
al - zer drin. Ja, das gibt es nur in W.

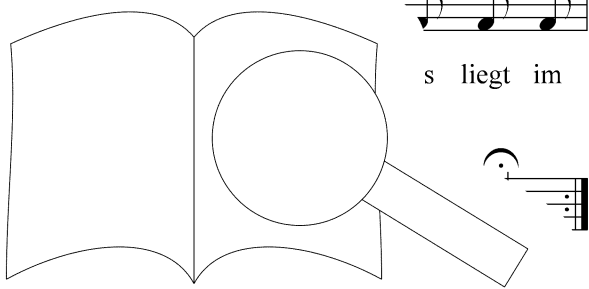

Intro

Klavier



Trian.

Bass dru.

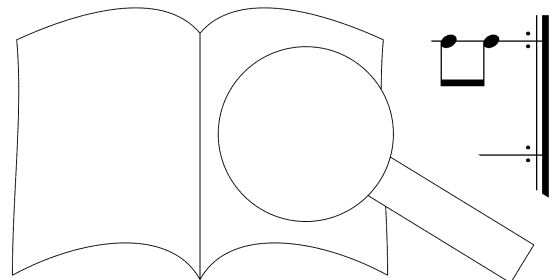

14 Gute Laune

Slowfox

and Musik: Rainer Butz

Moderate Swing (♩ = ♩₃)

♩ = 108

1.

An je-dem Mor-gen s ne Son-ne auf, der „Gu-te-Lau-ne-Ka-non“

4

2.

nimm Lauf. Uns geht's gut, das

7

wenn die Tö - ne sich chro - ma - tis heut' nicht al -

10

lein, auch n' zu o - der zu drei'n. Sing heut' im

13

4.

mit Baß und Te - nor. Auch Alt und So -

ran, fangt al - le nun an.

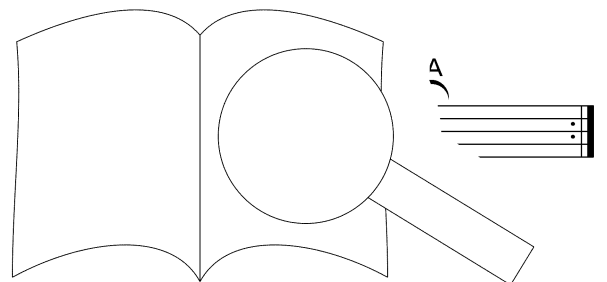

Moderate Swing (♩♩ = $\frac{1}{3}$ ♩)

Intro

Klavier

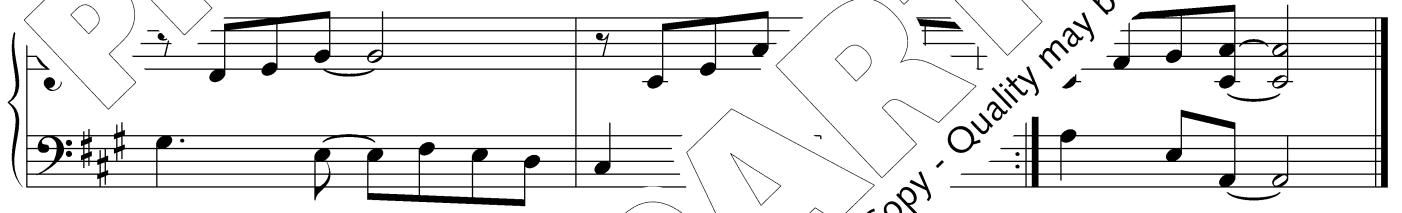

Schellenkranz



Bongos



Snar.

ohne Schnarrsaiten

rimshot

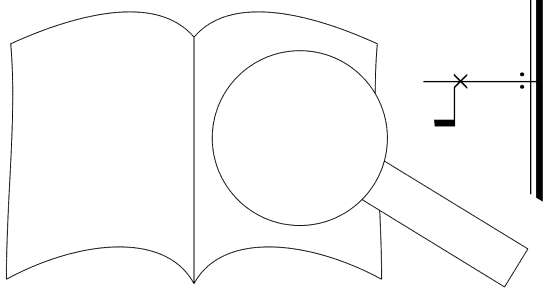
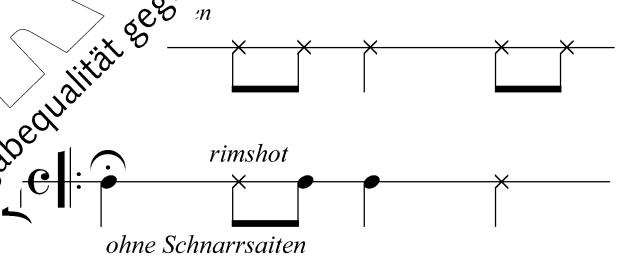

15 Müd'

Foxtrott

Text und Musik: Rainer Butz

1.
♩ = 176
Dm A⁷ A⁷

Müd' bin ich beim Auf - d', beim ins Bü - ro geh'n,

5 Gm Dm A⁷ Dm
ich bin immer - de und weiß nicht war - um.

2.
9 A⁷ Dm
g' am Mon - tag, gäh -

1 Dm A⁷
und je - den Tag gäh - ne mehr. Be - son - ders

3.
17 A⁷ A⁷
mü - de bin ich bei Mond - a - ber auch bei Son - nen - schein,

21 Gm A⁷ Dm
ob es re. mag, ich bin im - mer nur müd'.

4.
25 A⁷ Dm A⁷
nich jetzt schla - fen, fen.

Dm
Dann werd' ich viel - leicht ein - mal ganz w

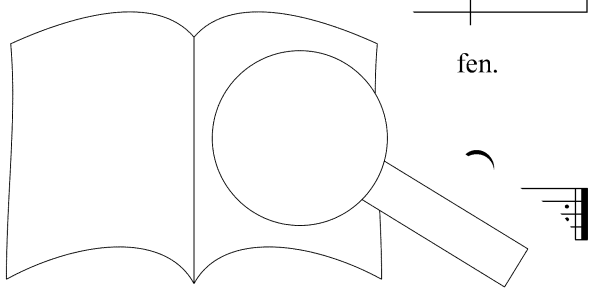

Intro

Klavier

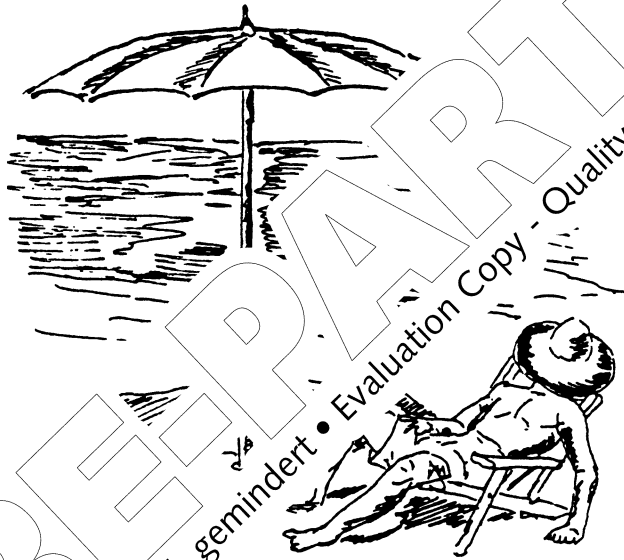

Tom-Toms

Hi H₂

Bass dru

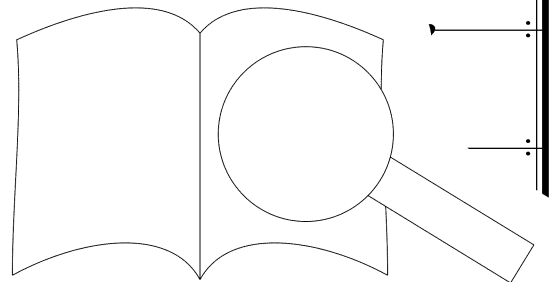

16 Tango-Jimmy

Tango

and Musik: Rainer Butz

♩ = 110

1.

Fm C7 m Bm Fm

Jim-my, der will tan-zen gehn, ma-de, ach, wie ist der Jim-my schön,

7 C7 Fm C C7

schaut ihn euch ha. Er trägt Jak-kett und Ho-sen vom De -

11 Des/F Fm Bm

ne glän-zen toll im hel-len Licht. An-icht die

14 C7

Mäd-chen schwach, doch die be-ach-tet der Wenn Jim-my dann in

18 C7 Des/F Fm

Schwung kommt, sein Terr er-füllt, dann se-hen

21 Bm C7 Fm C+ Fm

al-le ne und sei-ne Mie-ne wirkt un-ter-kühlt. A-ha.

25 4.

Des/F Fm

ist sein Le-bens-e-li-xier. Tan- bis ins Grab.

Fm

a-chen-herz zer-reißt und sich nach ihm ve

ultima volta

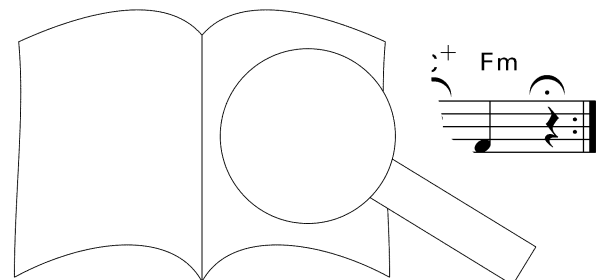

Intro

Klavier

 solo ultima volta

Kastagnetten

Hi Hat

Snare

17 Regenlied

Foxtrott

Text und Musik: Rainer Butz

♩ = 192 1.

Dip - i - dip - i - dip, der Re - ge

5 2.

die Bran - dung s, der Ne - bel schweb

9

i - dip - i - dip, Re - gen rinnt,

13 3.

Wind, sch, die Bran - dung b, webt. Und der Re - gen

17

rinnt, Re - gen rinnt, saust der Wind, sch,

21 4.

die s, der Ne - bel schwebt. Dip -

25

di - i - dip. Dip -

29

dip, dip - i - dip - i - di - i - dip. Dip -

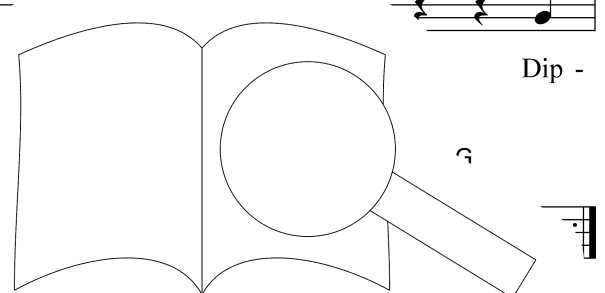

Intro

Klavier

First system of musical notation for the piano introduction, featuring a treble and bass clef with a key signature of one sharp (F#) and a common time signature (C). The melody in the treble clef starts with a quarter note G4, followed by eighth notes A4, B4, and C5. The bass clef accompaniment consists of quarter notes G2, B1, and C2.

Second system of musical notation for the piano introduction. The treble clef continues with eighth notes D5, E5, and F#5. The bass clef continues with quarter notes D2, F#2, and G2.

Third system of musical notation for the piano introduction. The treble clef continues with eighth notes A5, B5, and C6. The bass clef continues with quarter notes A2, C3, and D3.

Fourth system of musical notation for the piano introduction. The treble clef continues with eighth notes E6, F#6, and G6. The bass clef continues with quarter notes E3, G3, and A3. The system concludes with a double bar line and the instruction "2. Fine".

Hi Hat

Tom-

Bass dru

Musical notation for the Hi Hat, Tom, and Bass drums. The Hi Hat part consists of quarter notes on a single staff. The Tom part consists of quarter notes on a single staff. The Bass drum part consists of quarter notes on a single staff. A large graphic of a magnifying glass is overlaid on the drum notation.

PROBEPARTITUR
Ausgabequalität gegenüber Original evtl. gemindert • Evaluation Copy - Quality may be reduced • Carus-Verlag

18 Swinging Lips

Quickstep

and Musik: Rainer Butz

Swing ($\text{♪} = \text{♩}_3$)

$\text{♩} = 160$

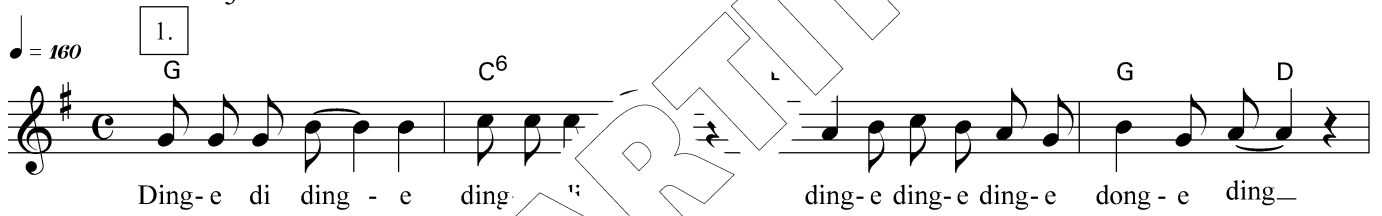
1. 

5 

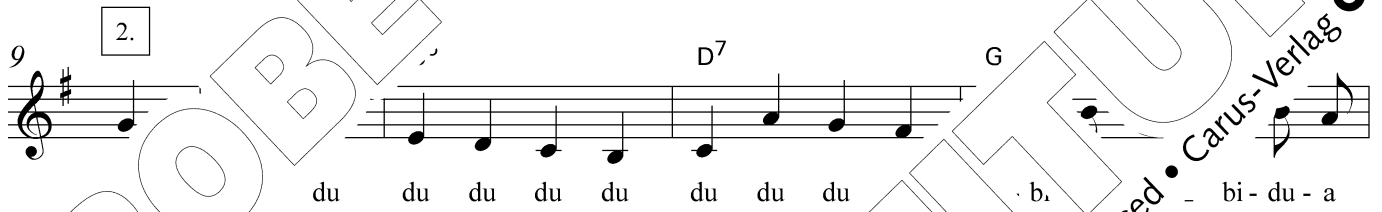
9 

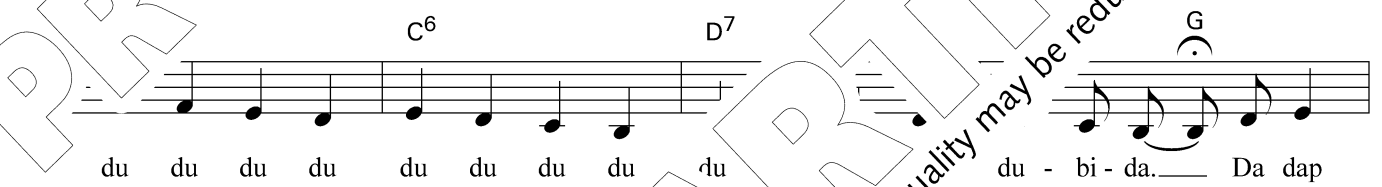

17 

21 

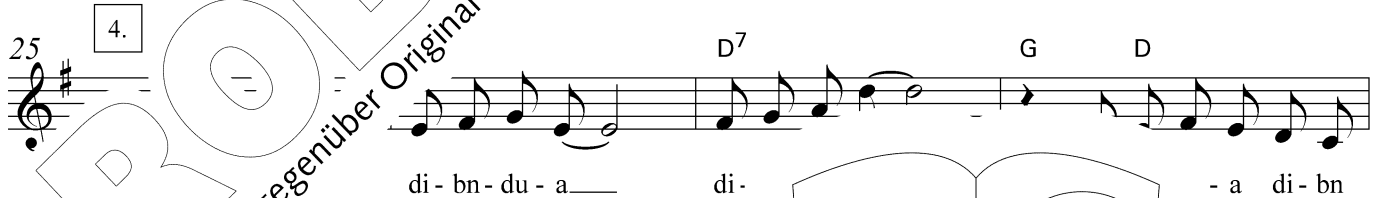
25 



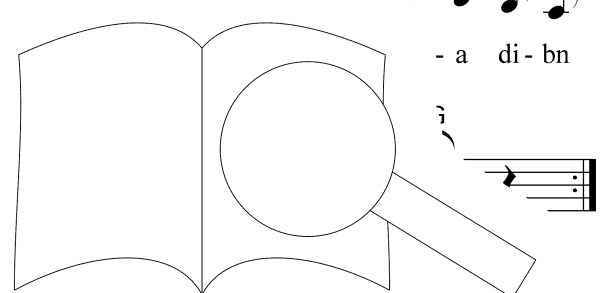

PROBEPARTITUR
Ausgabequalität gegenüber Original evtl. gemindert • Evaluation Copy - Quality may be reduced • Carus-Verlag

Swing (♩♩ = ♩₃)

Intro

Klavier

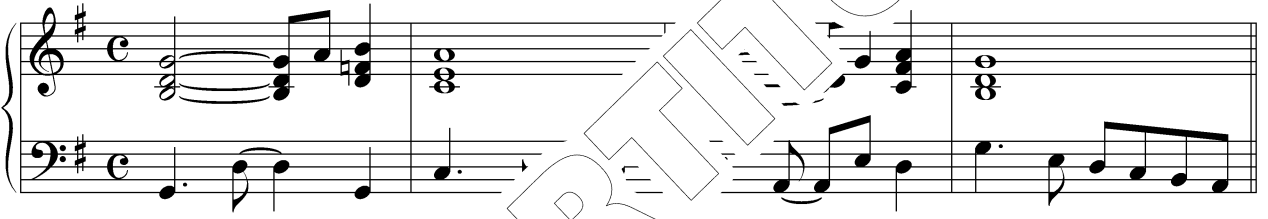

The piano introduction consists of two staves. The right hand starts with a series of chords and eighth notes, while the left hand provides a steady bass line with quarter notes.



The second system of piano notation continues the introduction with similar rhythmic patterns in both hands.



The third system of piano notation concludes the introduction with a final chord and a 'Fine' marking.

Hi Hat

Snare

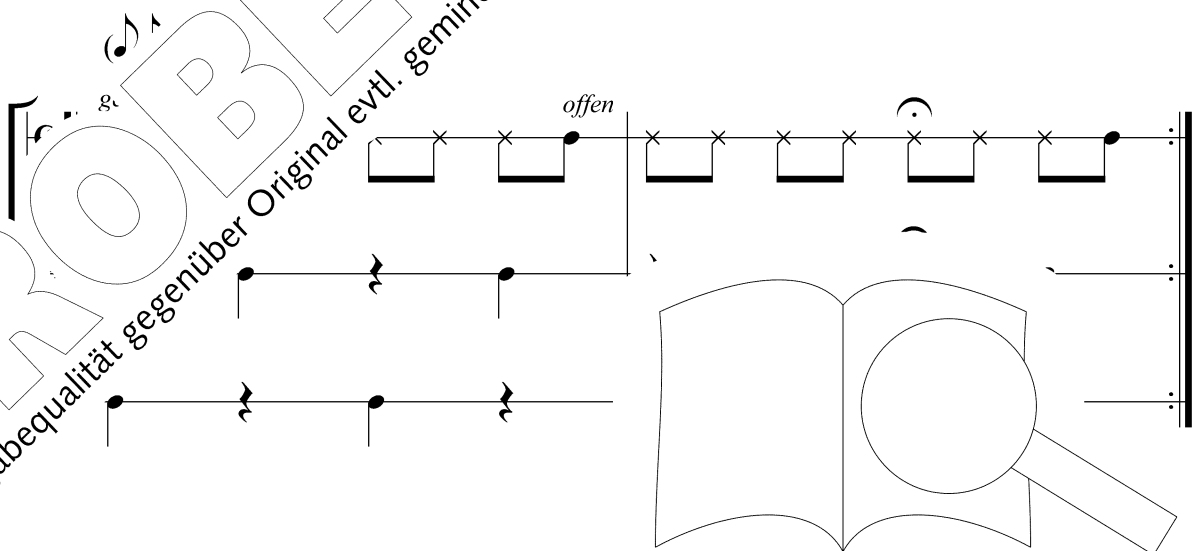

The drum notation includes a Hi Hat part with a 'gong' symbol and a 'Snare' part. The Hi Hat part features a rhythmic pattern of eighth notes with 'x' marks indicating cymbal hits. The Snare part shows a similar rhythmic pattern with dots indicating snare hits. The notation ends with a double bar line and repeat dots.

19 Rolling

Blues

and Musik: Rainer Butz

Moderate Swing (♩ = $\frac{1}{3}$)

1. $\text{♩} = 92$ F B F B C - B Bm C⁷

Roll-ing and roll-ing, roll-ing, roll-ing and roll-ing, roll-ing and roll-ing

2. F B G⁷ C F B

5 on. I'm sit-a-long the Mis-sis-sip-pi, be-c

3. C⁷ F B F

8 what a pit-y. I lost my job is fun-ny,

B Bm C⁷ B

but thanks to God my soul keep O how can I get some

14 F B G⁷ C B Bm C⁷

work and somed, tell me when will I feel good.

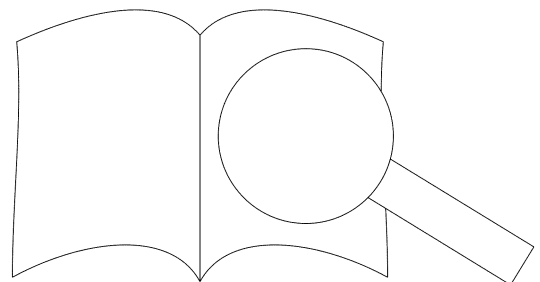
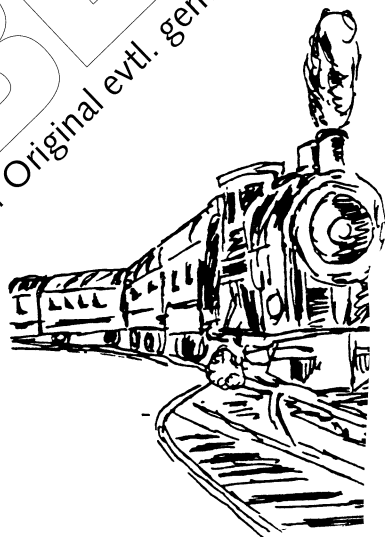

Moderate Swing (♩♩ = $\frac{1}{3}$ ♩)

Intro

Klavier

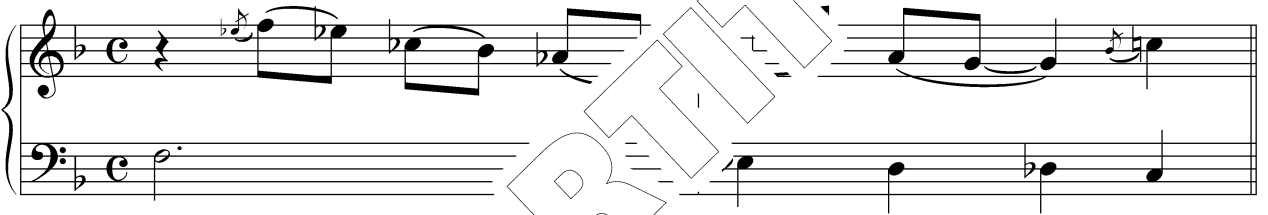

The piano introduction consists of two staves. The right hand starts with a quarter rest, followed by a series of eighth and quarter notes in a descending line. The left hand plays a simple bass line with quarter notes.



The first system of piano notation features a treble clef with a key signature of one flat and a common time signature. The melody is composed of eighth and quarter notes, with some slurs. The bass line consists of quarter notes.

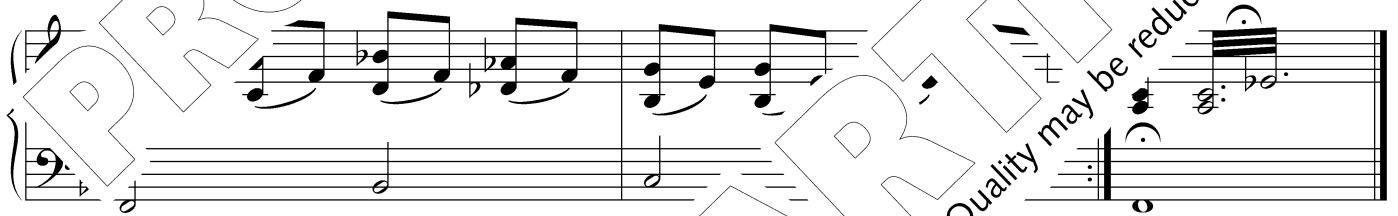

The second system of piano notation continues the melody and bass line from the previous system, ending with a double bar line.

Kastagnetten

Ride-Becken

Hi Hat

Bass

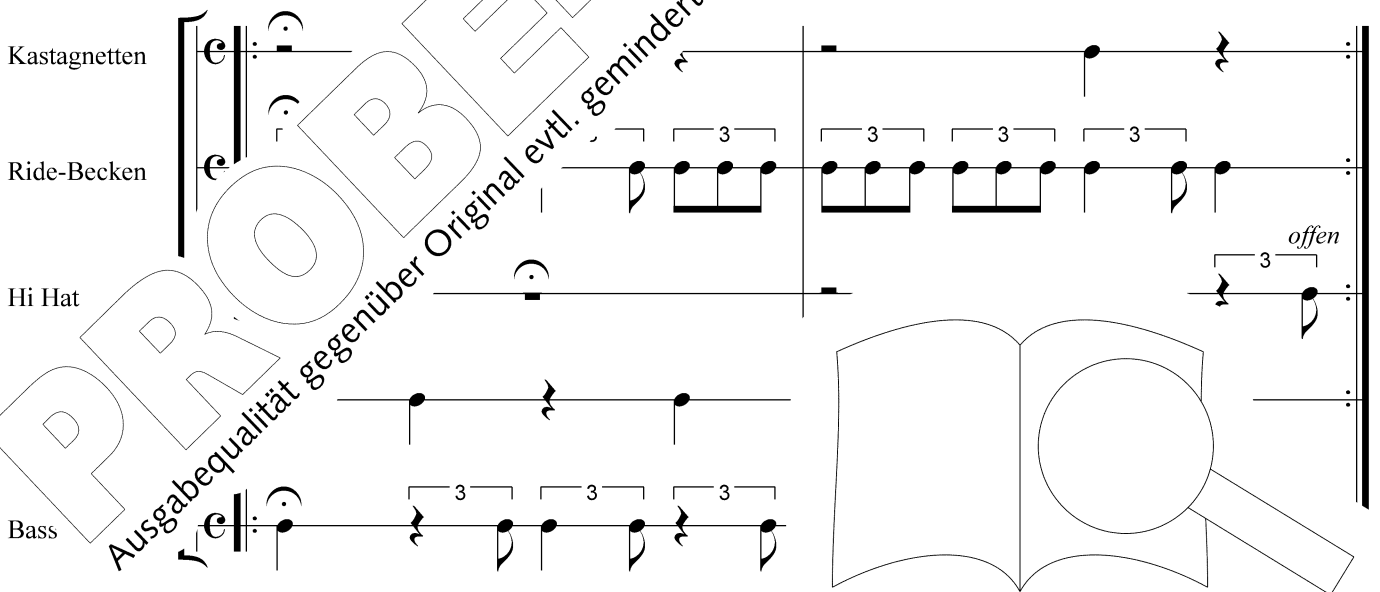

The percussion and bass section includes staves for Castagnettes, Ride-Becken, Hi Hat, and Bass. The Castagnettes and Hi Hat parts are mostly rests. The Ride-Becken part features a rhythmic pattern of eighth notes with triplet markings. The Bass part features a rhythmic pattern of quarter notes with triplet markings. A large magnifying glass graphic is overlaid on the bottom right of this section.

20 Fast Food

Zweifacher

nach trad. Überlieferung
Text und Satz: Rainer Butz

1. $\text{♩} = 152$
B

Män - ner und auch Frau'n, it ft zum Fast Food, hau'n

6 Cm F7 B B/F F7 B

sich drei, vier rein, schmek - ken ja so

11 2. Es6 F7

s groß, mit Ketch - up und blr - wie

1 F7 B Es F7 B

ist der Sa - lat so grün, - ta - min. So viel

21 3. F7

Men - schen strö - men da enn da schmeckt es recht. Wenn

26 Cm Es B/F F7 B

sie dan. um - wärts ziehn, ist al - len ga - ran - tiert ganz schlecht.

31 Es6 F7

die Ü - die

F7 B Es

scheint für sie

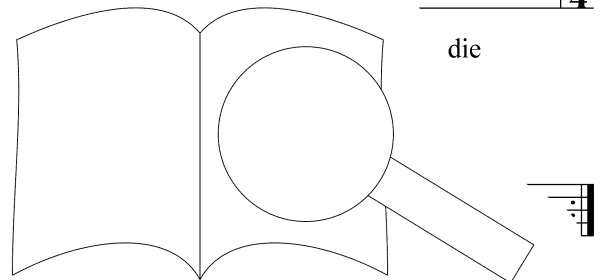

Intro

Klavier

Intro

Hi Hat

Snare

Bass drum

Hi Ha'

Bass a.

Musicals

Bender/Bredenbach: Unterwegs mit David	12.245
Bohm/Timm: Krach bei Bach	12.423
- Nachhall	12.578
Butz: Das Gold der Inkas	12.021
Führe: Der Elemaushund. 3 Theaterstücke mit Musik	12.427
- Gilgamesh	12.426
Gracie/Werner: Der kleine Elefant	12.898
Gschwandtner: Joseph und seine Brüder	12.243
Holdstock/Werner: Tod dem Minotaurus	12.899
Kay/Werner: Die berühmte Reise des Christoph Kolumbus	12.896
König/te Reh: Die Zauberharfe	12.000
- Immanuel – Immanuel	12.000
- La Piccola Banda	
- Ngoma-Bär	
- Magic Drum	
- MO(t)Z und ART(i)	
- Sammy	
Riegler: Es ist vollbracht. Musical zur Passionsgeschichte	
- Israel in Ägypten	
- König David	12.414
- Wir zeigen Gesicht	12.242
Rolf/Werner: Giant Finn	12.897
Schindler: SCHOCKORANGE – Ein Rhythmical	12.834
- Zirkus Furioso – Ein Zirkusmusical	12.826
- König Keks – Eine süß-scharfe Musical	12.820
- Max und die Käsebande – Ein Musical	12.811
- Geisterstunde auf Schloss Elisenstein	12.810
- Weihnachten fällt aus – Ein Musical	12.817
- Großer Stern, was nur ein Stern ist	12.818

Kinderhits mit Witz

Schindler: Kinderhits	12.808–12.833
-----------------------	---------------

Songs für Kinder

Schindler: Die Kinderlieder	12.803
- Dokt	12.807
- Eir	12.802
- Die kleine Welt	12.805
- Der Hund	12.804
- Die kleine Welt	12.806
- Der Hund	12.801
- Die kleine Welt	12.812

Opern, Kantaten und Singspiele

Lehmann: Der Froschkönig. Operette	12.410
Böckle: Die Heinzelmännchen	12.411
Bredenbach: Max & Moritz (Wilhelm Busch)	12.412
- Des Kaisers neue Kleider	12.413
Friedrich: Abenteuer der 4 Stadtmusikanten	12.414
Führe: Die Heinzelmännchen	12.415
Gramß: Der Wassermann in der Mühle	12.416
- Ein Käse für den König	12.417
- Zirkus Hallodria	12.418
Hein: Prahlschnauz und Krumpelschnütchen	12.419
Kretzschmar: Das Hemd des Glücklichen	12.420
- Der Rattenfänger von Hameln	12.421
- Der Seekrebs von Mohrin	12.422
- Die Bremer Stadtmusikanten	12.423
- Die Schildbürger	12.424
- Max und Moritz	12.401
- Münchhausen-Kantate	12.409
- Quix und Quax	12.411
- Till Eulenspiegel	12.405
- Vom neugierigen Hähnchen	12.418
Mayr: Mäuse in der Mühle	12.249
Mozart/Nagora: Der arme Heine	40.263
Rheinberger: Der arme Heine	50.153
- Der arme Heine	50.037
Schindler: Die kleine Welt	12.818
Schorr: Die kleine Welt	12.895

Geistliche

Böckle: Die Heinzelmännchen	12.575
Bredenbach: Max & Moritz (Wilhelm Busch)	12.572
- Des Kaisers neue Kleider	12.573
Friedrich: Abenteuer der 4 Stadtmusikanten	12.574
Führe: Die Heinzelmännchen	12.570
Gramß: Der Wassermann in der Mühle	12.571
- Ein Käse für den König	12.250
- Zirkus Hallodria	12.540
Hein: Prahlschnauz und Krumpelschnütchen	12.541
Kretzschmar: Das Hemd des Glücklichen	12.539
- Der Rattenfänger von Hameln	12.542
- Der Seekrebs von Mohrin	12.543
- Die Bremer Stadtmusikanten	12.544
- Die Schildbürger	12.561

- Die Heilung der Blinden	12.546
- Die Hunde des I	12.548
- Die Kinderer	12.549
- Die Stillun	12.550
- Ein Ster	12.551
- Elija	12.552
- Fre	12.562
- Lehemia)	12.555
- Grenzen (Heilung d. Naeman)	12.547
- Mensch)	12.553
- ht der Welt	12.538
- ein Binsenkorb Hoffnung	12.554
- und seid froh	12.563
- und der Kämmerer	12.557
- Sündenfall	12.558
- Singspiel zu Passion u. Ostern (Töchterlein d. Jairus)	12.560
- Singspiel zur Weihnachtsgeschichte	12.559
- Strecke deine Hand aus	12.545
Graf: Il est né, le divin enfant	12.238
- Wachet auf, ruft uns die Stimme	12.239
Horn: Psalm 23. Der Herr ist mein Hirte	12.528
- Weihnachtskantate	10.494
- Weihnachtsgeschichte	12.235
Janca: Hört, der Engel helle Lieder	12.236
Kretzschmar: David und Goliath	12.237
- Der blinde Bettler	12.238
- Der Samaritaner	12.239
- Der Turmbau zu Babel	12.240
- Die große Flut	12.241
- Drei Stücke für den Gottesdien	12.233
- Geboren im Jahre Null. We	12.408
- Gott ist mein Hirte	12.233
- Hast du deinen Brude	12.531
- Pharisäer und Zöllr	12.232
- Siehe, dein Köni	12.212
- Vier Weihnar	12.213
Nickel: Simc	12.253
Rothaupt	12.254
Schwei	12.534
- Er	12.533
- lagt i	12.513
- Kinc	12.520

- Chor	12.248
- g für Kinder	12.251
- Pädagogik aus dem Beethovenhaus	47.706
- dem Beethovenhaus	47.707
- en	47.716
- en	12.576
- Für alle ist Christus geboren	12.577
- in unsern Kinderchor	12.315
Bredenbach: Heiteres & Weiteres (Wilhelm Busch)	12.317
- Vom Wünschen & Zaubern	12.317
Buchenberg: Gulla, mille gullala bona	12.322
Butz: Gute-Laune-Kanons	12.902
Chorissimo – Chorbuch für die Schule	2.200
Freiburger Kinderchorbuch	12.075
Hodie Christus natus est, Heft I	2.099
Kinderleicht. Ein Lieder-Bilderbuch (0-4 Jahre)	12.077
König/te Reh: Freundschaft mit Afrika	12.009
- Morgensternlieder	12.010
Kretzschmar: Die Schlange Serpentina	12.702
- Dunkel war's, der Mond schien helle	12.701
- Mantje, Mantje, timpe te	12.417
- Rambamburu	12.415
List: Mobv	12.321
Nees:	12.323
Schr	9.901
- W	9.902
Świk	40.718
Witt	12.320
Züg	12.404
Leh	12.304
Ste	12.304
Trü	12.304
- fü	12.304
- Si	12.304
- Si	12.304
- St	12.304
- Ein kommentiertes Singsp. ...	12.4019

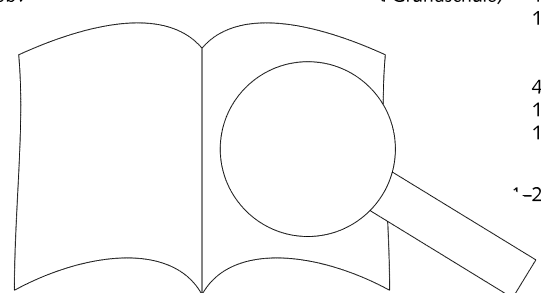

PROBE-PARTITUR
 Ausgabqualität gegenüber Original evtl. gemindert • Evaluation Copy - Quality may be reduced • Carus-Verlag