

Max REGER

Monologe op. 63
Heft 2

herausgegeben von / edited by
Alexander Becker, Christopher Grafschmidt,
Stefan König und Stefanie Steiner-Grage

Einzelausgabe aus der / Separate edition from
Reger-Werkausgabe
Abteilung I: Orgelwerke
Band 5: Orgelstücke I

Editionsleitung / Editorial Directors:
Susanne Popp und Thomas Seedorf

Für Vorwort und Kritischen Bericht verweisen wir auf den
Band der Werkausgabe sowie die zugehörige DVD.
Die DVD ist auch separat erhältlich.

For Foreword and Critical Report please refer to the volume
from the Werkausgabe and the respective DVD.
The DVD is also available separately.

9

scen - - - - - do

Detailed description: This system contains measures 9 and 10. The music is in a key with two flats (B-flat and E-flat) and a 3/4 time signature. The right hand features a complex melodic line with many sixteenth notes and a triplet of eighth notes in measure 9. The left hand provides a steady accompaniment with quarter and eighth notes. The lyrics 'scen' and 'do' are positioned below the vocal line.

11

do ff + CI ff

Detailed description: This system contains measures 11 and 12. The music continues with similar rhythmic patterns. The right hand has a melodic line with some slurs. The left hand has a bass line with some rests. The lyrics 'do' are present. Dynamic markings include 'ff' (fortissimo) and '+ CI' (crescendo). A large watermark 'PROBEPARTITUR' is overlaid diagonally across the page.

13

pìù ff e cre do fff

pìù ff e cre fff

Detailed description: This system contains measures 13 and 14. The music features a more active accompaniment in the left hand. The right hand has a melodic line with some slurs. The lyrics 'pìù ff e cre' and 'do' are present. Dynamic markings include 'pìù ff e cre' and 'fff' (fortississimo). The tempo marking 'poco rit.' (poco ritardando) is written above the right hand in measure 14.

15

a tempo subito

Detailed description: This system contains measures 15 and 16. The music starts with a new section marked 'a tempo subito'. The right hand has a melodic line with some slurs. The left hand has a bass line with some rests. The tempo marking 'a tempo subito' is written above the right hand in measure 15. A large watermark 'PROBEPARTITUR' is overlaid diagonally across the page.

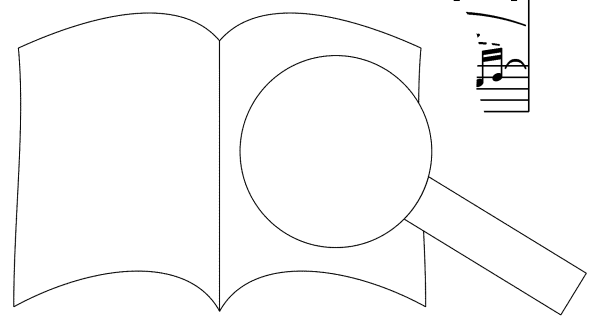

18

21

scen

scen

23

26

san - do

a tempo

do

fff

II. Man

pp

do

fff

PROBEPARTITUR

Ausgabequalität gegenüber Original evtl. gemindert • Evaluation Copy - Quality may be reduced • Carus-Verlag

29

ppp

- C I, II, III

ppp

32

poco ritenuto

molto

ppp

a tempo

I. Man *f e cre*

+ C II, r

cre

35

scen

scen

3

3

37

do

pù f

do

39

scen - - - do

ff + C III

scen - - - do *ff* + C I

41

sempre cre - - - - - scen

sempre cre

44

do più *ff* e se

do più *f* e cre

47

PROBEPARTI
 Ausgabequalität gegenüber Original evtl. gemindert • Evaluation Copy - Quality may be reduced • Carus-Verlag

Nr. 6 Passacaglia

Andante con moto (♩ = 78)

III. Man *ppp* 8'

8', 16'

ppp

The first system of the musical score for 'Nr. 6 Passacaglia'. It consists of two staves. The upper staff is in treble clef and the lower staff is in bass clef. The key signature has three flats (B-flat, E-flat, A-flat) and the time signature is 3/4. The tempo is 'Andante con moto' with a quarter note equal to 78 beats per minute. The system begins with a fermata over the first measure. A dynamic marking of *ppp* is present. A bracketed section in the upper right is labeled 'III. Man *ppp* 8''.

10

The second system of the musical score, starting at measure 10. It continues with the same key signature and time signature. The music features a melodic line in the upper staff and a supporting bass line in the lower staff.

16

un poco meno ppp

un poco m^r

The third system of the musical score, starting at measure 16. It includes dynamic markings: *un poco meno ppp* in the upper staff and *un poco m^r* in the lower staff.

21

The fourth system of the musical score, starting at measure 21. It concludes the piece with a final melodic phrase in the upper staff and a sustained bass line in the lower staff.

PROBENPARTITUR
Ausgabequalität gegenüber Original evtl. gemindert • Evaluation Copy - Quality may be reduced • Carus-Verlag



26

scen

scen

31

do *p* + 4' e sempre poco a poco cre

+ C III

do *p* e sempre poco a

34

37

scen

scen

PROBEPARTITUR

Ausgabequalität gegenüber Original evtl. gemindert • Evaluation Copy - Quality may be reduced • Carus-Verlag

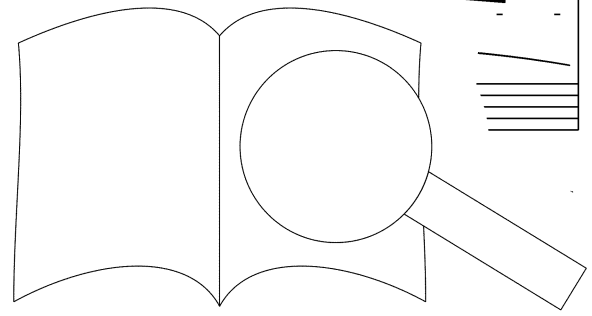

40

II. Man

do

mf

(III. Man)

do

mf

43

46

II. Man *f*

+ C II

f

49

PROBENPARTITUR

Ausgabequalität gegenüber Original evtl. gemindert • Evaluation Copy - Quality may be reduced • Carus-Verlag

52

55

I. Man 8', 4'

ff

(II. Man) 8', 4'

58

di

poco a poco di

61

mi nu en do

nu

PROBENPARTIEMUR

Ausgabequalität gegenüber Original evtl. gemindert • Evaluation Copy - Quality may be reduced • Carus-Verlag

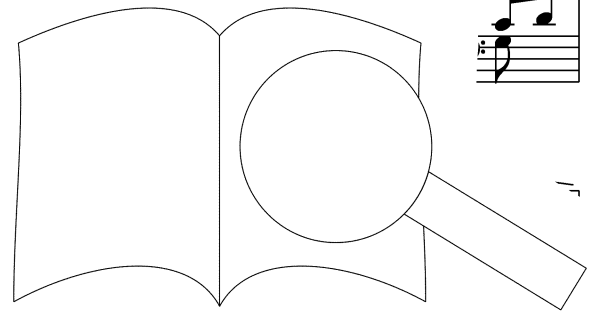

III. Man 8', 16', 4'

64

pp e sempre poco a poco cre - - - - -
(II. Man) 8' (nur äußerst zart hervortretend)

- C II, III

pp e sempre poco a poco cre - - - - -

67

scen - - - - -

scen - - - - -

70

I. Man 8' *tr*

I. Man) 8', 4'

do *f*

+ C II, III

73

75

f

77

79

(I. Man)
2
p
più f
più f

81

PROBEPARTITUR

Ausgabequalität gegenüber Original evtl. gemindert • Evaluation Copy - Quality may be reduced • Carus-Verlag

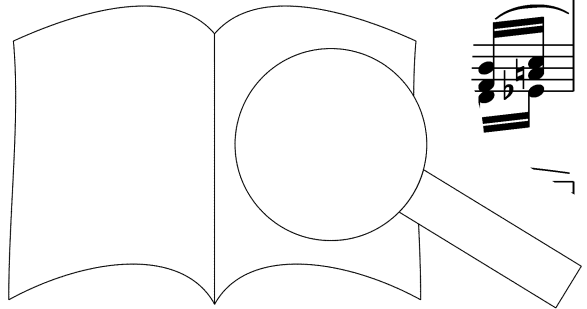

84

Musical score for measures 84-86. The score is written for piano in three staves: two treble clefs and one bass clef. The key signature has three flats (B-flat, E-flat, A-flat). The music features complex rhythmic patterns with many rests and slurs.

87

Musical score for measures 87-88. The score is written for piano in three staves. Measure 87 continues the previous system. Measure 88 features a first ending marked "I. Man ff" and a triplet of eighth notes in the right hand. The key signature remains three flats.

89

Musical score for measures 89-90. The score is written for piano in three staves. Both measures feature dense, continuous sixteenth-note passages in both the right and left hands. The key signature remains three flats.

91

Musical score for measures 91-92. The score is written for piano in three staves. Measure 91 continues the sixteenth-note passages. Measure 92 features a more melodic line in the right hand with some rests. The key signature remains three flats.

PROBEPARTITUR

Ausgabequalität gegenüber Original evtl. gemindert • Evaluation Copy - Quality may be reduced • Carus-Verlag

93

95

H. Man

sempre *f*

sempre *ff*

97

100

PROBEPARTITUR

Ausgabequalität gegenüber Original evtl. gemindert • Evaluation Copy - Quality may be reduced • Carus-Verlag

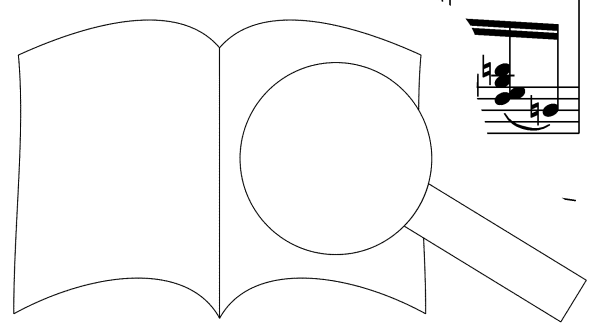

103

I. Man *più ff*

+ CI
più ff

106

109

112

fff

115

118

un poco di - - mi - - nu - - en - - dc

un poco di - - mi - - nu - -

121

II. Man **f**

III. Man **p**

125

I. Man **f**

Man)

PROBEPARTITUR

Ausgabequalität gegenüber Original evtl. gemindert • Evaluation Copy - Quality may be reduced • Carus-Verlag

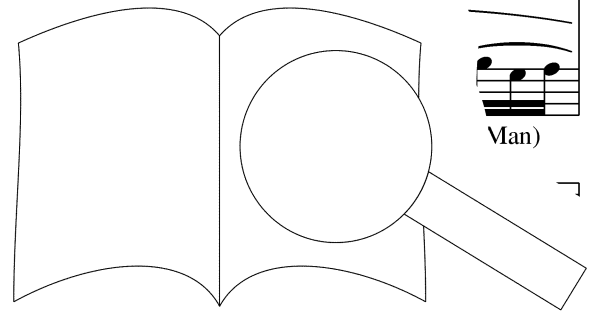

129

(I. Man)

I. Man

+ CI

f

132

135

137

PROBEPARTITUR

Ausgabequalität gegenüber Original evtl. gemindert • Evaluation Copy - Quality may be reduced • Carus-Verlag

139

141

143

ff (I. Man)

+ C III

145

erweise c^2 ; siehe Kritischer Bericht. / Possibly c^2 ; see the Critical Report.

147

Musical score for measures 147-148. The score is written for piano and features a complex texture with multiple voices. The right hand has a melodic line with many sixteenth notes, while the left hand provides a harmonic accompaniment with chords and moving lines. A fermata is placed over a measure in the lower left voice.

149

Musical score for measures 149-150. The texture continues with intricate melodic and harmonic patterns. The right hand maintains a fast-moving melodic line, and the left hand provides a steady accompaniment.

151

più ff

Musical score for measures 151-152. The dynamic marking *più ff* (piano fortissimo) is indicated. The music becomes more dramatic with thicker chords and more intense melodic passages. The right hand features a series of chords, and the left hand has a more active, rhythmic accompaniment.

153

Musical score for measures 153-154. The score concludes with a final cadence. The right hand has a series of chords, and the left hand has a rhythmic accompaniment. The piece ends with a final chord in the right hand.

PROBEEPARTITUR

Ausgabequalität gegenüber Original evtl. gemindert • Evaluation Copy - Quality may be reduced • Carus-Verlag

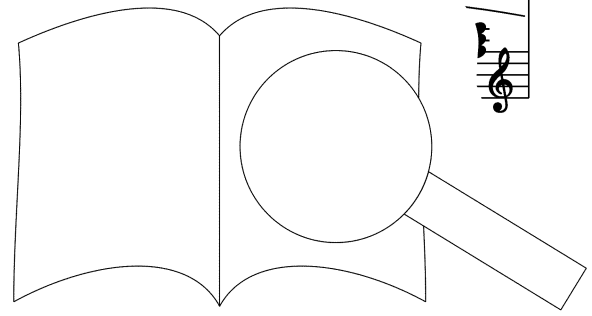

155

158

160

162

164

166

più fff e sempre c'

169

scer

173

apre ritardando *Adagio*

Nr. 7 Ave Maria!

Andante sostenuto (ma con moto)

III. Man [8', 4'] *ppp* II. Man 8' *pp* (III. Man 8', 4') *ppp*

The first system of the musical score for 'Nr. 7 Ave Maria!'. It consists of three staves. The top staff is the right hand, starting with a treble clef, a key signature of two sharps (F# and C#), and a 6/8 time signature. It contains a melodic line with various ornaments and dynamics, including *ppp* and *pp*. The middle staff is the left hand, starting with a bass clef, the same key signature and time signature, and contains a harmonic accompaniment. The bottom staff is a separate bass line, also in bass clef, with a 6/8 time signature and a *ppp* dynamic. Performance markings include 'III. Man [8', 4']', 'II. Man 8'', and '(III. Man 8', 4')'.

5 *espressivo*

The second system of the musical score, starting at measure 5. It continues the three-staff format. The top staff features a more active melodic line with the marking *espressivo*. The middle and bottom staves continue their respective parts. A large watermark 'PROBEPARTITUR' is visible across the system.

8 *pp* *meno pp*

The third system of the musical score, starting at measure 8. The top staff has dynamics of *pp* and *meno pp*. The middle and bottom staves continue. The watermark 'PROBEPARTITUR' is still present.

11 *molto*

The fourth system of the musical score, starting at measure 11. The top staff has a *molto* dynamic marking. The middle and bottom staves continue. The watermark 'PROBEPARTITUR' is still present.

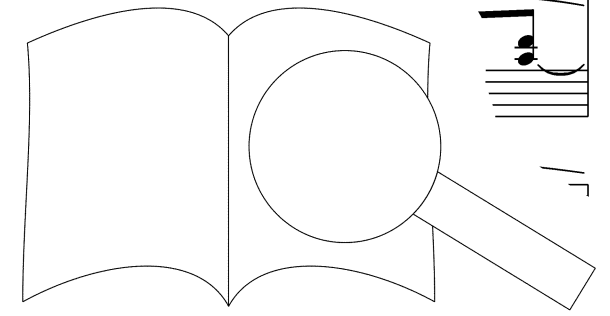

PROBEPARTITUR
Ausgabequalität gegenüber Original evtl. gemindert • Evaluation Copy - Quality may be reduced • Carus-Verlag

14

f *mf*

17

p

20

pp *stringendo* *sempre agitato*

p *e cre*

t. Man

meno p e cre

23

(III)

f *do* *di*

f *scen* *do*

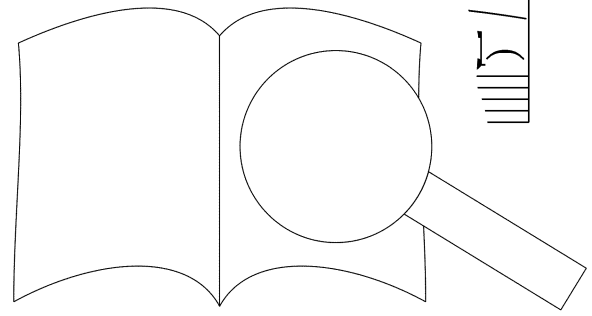

26

mi - nu - en - do *p* *mf* *ff*

mi - nu - en - do *p* *mf* *ff*

poco ritardando

Tempo primo (Andante con moto)
II. Man (8')

29

pp

(III. Man 8', 4')

pp

32

quasi f

p

35

molto *essivo* *pp*

PROBENPARTIUR

Ausgabequalität gegenüber Original evtl. gemindert • Evaluation Copy - Quality may be reduced • Carus-Verlag

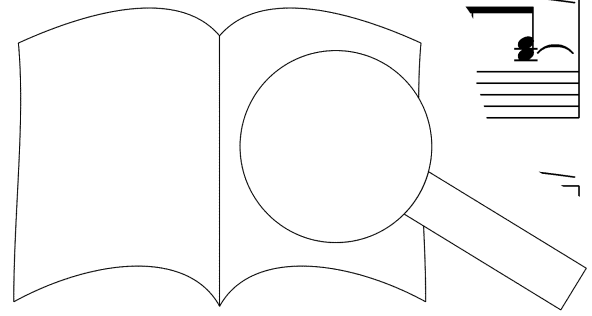

38

meno **pp** **f**

41

poco ritardando *a tempo*

pp *III. Man più pp*

pp *più pp*

44

quasi f mi - - -

sempre *di - - - - - mi - - -*

47

nv. en - - - - - da

en en - - - - -

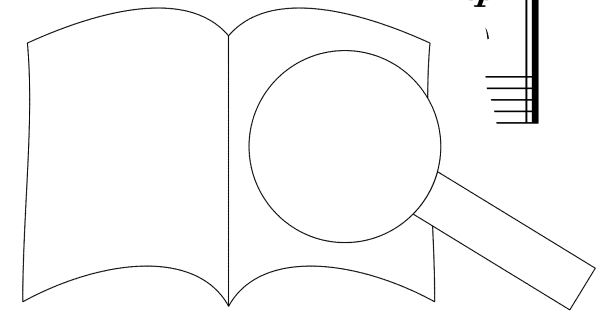

PROBENPARTIUR
Ausgabequalität gegenüber Original evtl. gemindert • Evaluation Copy - Quality may be reduced • Carus-Verlag

Nr. 8 Fantasie

Vivace (♩=92)

II. Man *mf* 8', 4'

sempre mf

mf

This system contains the first two staves of the musical score. The upper staff is in treble clef and the lower staff is in bass clef. The music is in 4/4 time. The first staff begins with a dynamic marking of *mf* and a tempo marking of *sempre mf*. The second staff continues the melody with a dynamic marking of *mf*.

4

p

This system contains the third and fourth staves. The upper staff starts with a measure rest for 4 measures. The music continues with a dynamic marking of *p* (piano).

7

mf [e] cre

This system contains the fifth and sixth staves. The upper staff begins with a measure rest for 7 measures. The music continues with a dynamic marking of *mf* and the lyrics "[e] cre".

9

scen

This system contains the seventh and eighth staves. The upper staff begins with a measure rest for 9 measures. The music continues with the lyric *scen*.

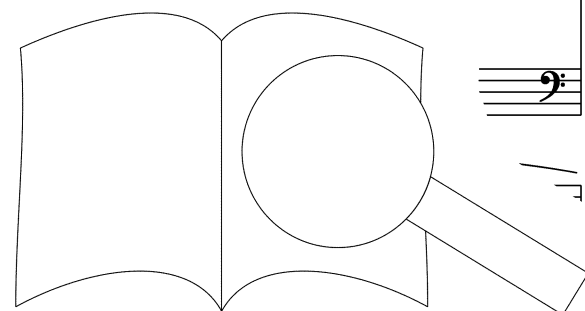

PROBEPARTITUR
Ausgabequalität gegenüber Original evtl. gemindert • Evaluation Copy - Quality may be reduced • Carus-Verlag

11

f (II. Man)
I. Man*

f

13

sempre f e cre - - - - -
II. Man

15

do

17

ff

* T_a . wohl irrtümlich II. Man; siehe Kritischer Bericht. / In the first edition *probal*



19

21

poco rit.

sempre ff

a tempo (Vivace ♩ = 92)

tr

I. Man
p ma *sempre poco* a *poco* *r*

I. Man

sempre ff

24

26

mp

cre

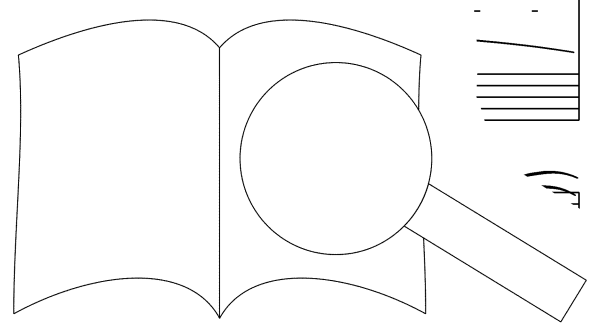

28

scen

scen

30

f

f

32

34

poc

poco meno mosso (ma vivace)

II. Man

p e cre

do

fff

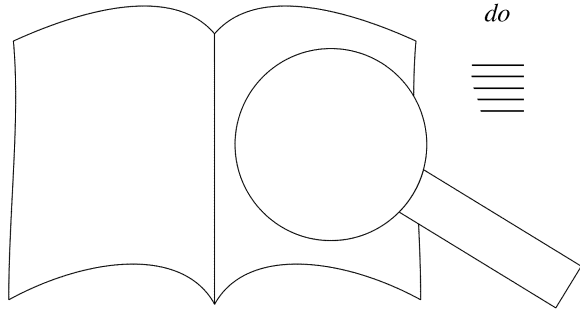

(35)

f *fff* I. Man più *fff*

37

poco a poco ritardando (*quasi Adagio*)

di - - - mi - - - nu

fff

38 **Tempo primo** (*Vivace* $\text{♩} = 92$)

(I. Man) *p* e poco a poco cre

p e poco

sempre un poco str^o

41

scen

p e poco

PROBEPARTITUR

Ausgabequalität gegenüber Original evtl. gemindert • Evaluation Copy - Quality may be reduced • Carus-Verlag

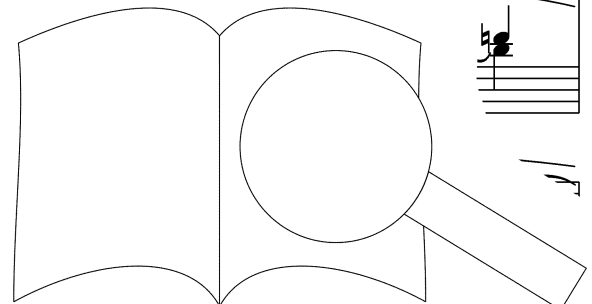

gen - - - - - do

43

Più vivace (♩ = 108)

45

f e sempre poco a poco cre - - -

f e sempre poco a

47

scen

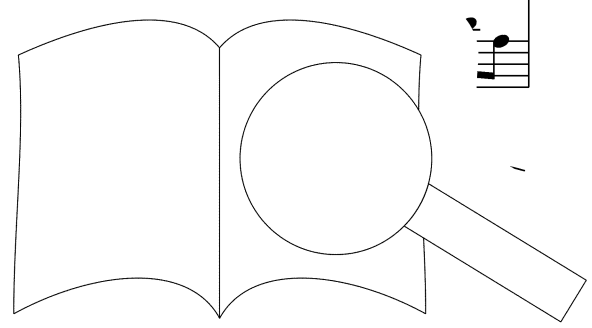

49

scen ff

scen ff

Detailed description: This system contains two systems of musical notation. The first system has a treble clef staff with a melodic line and a grand staff (treble and bass clefs) with a harmonic accompaniment. The second system has a bass clef staff with a single melodic line. Both systems include the dynamic marking 'ff' and the word 'scen'.

51

Detailed description: This system contains two systems of musical notation. The first system has a treble clef staff with a melodic line and a grand staff with a harmonic accompaniment. The second system has a bass clef staff with a single melodic line.

53

ff

stardando

quasi Adagio

do Org Pl

Detailed description: This system contains two systems of musical notation. The first system has a treble clef staff with a melodic line and a grand staff with a harmonic accompaniment. The second system has a bass clef staff with a single melodic line. The first system includes the dynamic marking 'ff', the tempo marking 'stardando', and the word 'do'. The second system includes the tempo marking 'quasi Adagio' and the text 'Org Pl'. A large magnifying glass graphic is overlaid on the bottom right of the system.

PROBEPARTITUR

Ausgabequalität gegenüber Original evtl. gemindert • Evaluation Copy - Quality may be reduced • Carus-Verlag